

Operating instructions Pump Series

5G13...

5G21...

5G35...

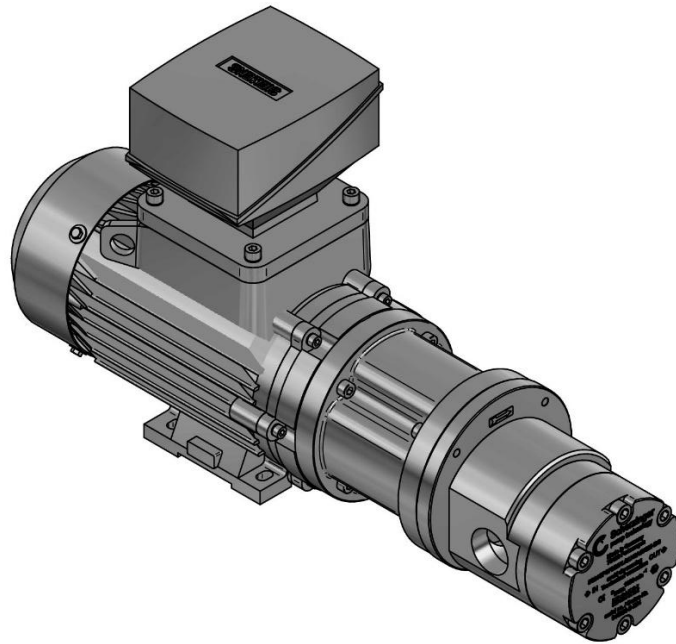

© by Scherzinger Pumpen GmbH & Co. KG

Version: 2.0.1 German

Date: 07.09.2022

Author: R.Heizmann

Release: M. Tritschler



© by **Scherzinger Pumpen GmbH & Co. KG**

The copyright to this documentation remains with **Scherzinger Pumpen GmbH & Co. KG**, 78120 Furtwangen / Germany.

The content of this documentation (texts, illustrations, drawings, graphics, plans, etc.) may not be reproduced or distributed, in whole or in part, without our written consent, or may not be used without authorization or handed over to third parties or made accessible for the purposes of the competition.

Scherzinger Pumpen GmbH & Co. KG

Bregstraße 23-25
78120 Furtwangen / Deutschland

Phone: +49 7723 6506-0

E-Mail: info@scherzinger.de

Internet: www.scherzinger.de

Manual:	Operating instructions
Output:	2.0.0 German
Date of issue:	17.03.2026

Design and product changes that serve to improve the product, are reserved.

Table of Contents

1	Introduction	5
1.1	Foreword	5
1.2	Product Identification / Product Information	5
1.3	Storage	5
1.4	Definition of the term	6
1.5	Representations abroad	6
1.6	Symbolism in this manual	7
1.6.1	Hazard warning levels	7
1.6.2	Specific Hazard Symbols	8
1.6.3	Common Symbols	8
1.7	Personal protective equipment	8
1.8	Definition of skilled workers / authorized personnel	8
1.9	Obligation of the operator	9
1.10	Obligation of the staff	10
1.11	Marking using the example of the pump type 5G21SPSPMMAL/M.N8A#5GM-ID8	11
1.12	Intended use / normal operation	12
1.12.1	Limit values	13
1.12.2	Temperature classes and permissible temperatures	14
1.12.3	Series Overview / Wetted Parts	14
1.12.4	Design Printing and Design Temperature (MAWP and MAWT)	15
1.12.5	Painting	15
1.12.6	Maximum possible speed	15
1.13	Improper use / interference	16
1.13.1	Hazard from dust	16
1.13.2	Hazard due to dry running of the pump	16
1.13.3	Hazard of overheating of the pump	16
1.13.4	Danger from overpressure	17
1.13.5	Hazard from particles/foreign substances in the medium	17
1.13.6	Hazard from operating at too high a speed	18
1.13.7	Exposure to electricity	18
1.13.8	Hazard of exceeding the maximum torque	18
1.13.9	Hazard from mechanically generated sparks	18
1.14	The complaint	19
1.15	Warranty and liability	19
1.16	Declaration of Conformity	20
1.16.1	Declaration of conformity according to Directive 2014/34/EU	20
1.16.2	Declaration of conformity according to Directive 2006/42/EC (Machinery Directives)	21
1.16.3	Notes on CE conformity regarding the installation of a motor / drive	22
1.17	Declaration of Non-Objection	23
2	Safety instructions	24
2.1	Hazard from hot components	24
2.2	Danger from electric shock	24
2.3	Hazard from magnetic fields	25
2.4	Exposure to pumped media	25
2.5	Hazard due to pump weight	25
2.6	Information on explosion protection	25
2.6.1	Target group	26
2.6.2	Safety devices	26
2.6.3	Ignition hazards and protective measures	26
2.6.4	Temperature limits	27
2.6.5	Ex marking	27
3	Transport and interim storage	29
3.1	Shipment of the pump and protective measures	29
3.2	Interim storage	29
3.3	Preservation for storage after operation / flushing of the pump	30
3.4	Return to the factory	30
4	Functionality / Description	31
4.1	Function of the pump	31
4.2	Structural design of the pump	32
4.2.1	Pump body	32
4.2.2	Magnetic coupling	35
4.2.3	Bearing bushes	36
5	Installation / Assembly / Disassembly	37
5.1	Additional information when using the pump in a potentially explosive environment	37
5.2	Information on the location	38

5.3	Installation position.....	38
5.4	Mounting the magnetic coupling.....	39
5.5	Assembly / disassembly of motor flange and drive unit.....	40
	Always carry out assembly work with the drive unit switched off.....	41
5.6	Connecting cables.....	41
6	Commissioning / Decommissioning	43
6.1	Additional information when using the pump in a potentially explosive environment	43
6.2	Prerequisite for commissioning	43
6.3	Commissioning.....	44
6.4	Monitoring	44
6.5	Decommissioning.....	45
7	Maintenance / Cleaning	46
7.1	Additional information when using the pump in a potentially explosive environment	46
7.2	Safety instructions for maintenance, inspection and assembly work.....	46
7.3	Maintenance cycle	47
8	Fault, causes and elimination	48
9	Components	50
9.1	Bill of Materials.....	50
10	Technical data	51
10.1	Connection dimensions on the engine side.....	51
10.1.1	PK version	51
10.1.2	MK version	51
10.1.3	ZK version	52
10.2	Connection dimensions on the pump side and motor connection	53
10.2.1	Motor version with connection according to DIN ISO 228 or ANSI B1.20.1.....	54
10.2.2	Motor version with connection for SAE-ISO 6162-1	54
10.2.3	Motor version with flange EN 1092-1	55
10.3	Sound pressure level	55
10.4	Non-ionizing radiation	55
	Disposal.....	56
10.5	Disposal of the pumped medium.....	56
11	Appendix.....	57
11.1	Revision List.....	57
11.2	Signature list	58

1 Introduction

1.1 Foreword

This operating manual from **Scherzinger Pumpen GmbH & Co. KG** is part of the product (pump).

The operating instructions are intended for all people who carry out assembly, installation, commissioning and service work on the product (pump).

Please read these operating instructions carefully and pay particular attention to the safety instructions!

If you have any questions regarding the product (pump), its area of application or any other questions, our team will be happy to assist you.

1.2 Product Identification / Product Information

Validity

The descriptions in this operating manual refer exclusively to the product (pump) as described in the technical data ([Technical Data](#)) and as developed and built by the manufacturer.

Product Information

The pump from Schertzinger Pumpen GmbH & Co. KG is suitable for pumping liquids that do not have a corrosive or aggressive effect on the materials used (wetted parts).

Applicable documents

Documents that are not included in the operating instructions but are included has to be considered to be co-valid documents. If any of the documents listed below are missing, please contact the manufacturer. Applicable documents are:

- Technical documentation/operating instructions of the motor manufacturer,
- PTB (Physikalisch-Technische Bundesanstalt) certificate from the motor manufacturer,
- Optional: Technical documentation of the accessories.

Do you assembly or do you operate the machine, you must read and understand the applicable documents before installing and commissioning the machine. Make sure that these documents are always kept at the point of use of the machine.

1.3 Storage

This **operating manual** must always be kept close to the product (pump) to be quickly accessible when needed.

1.4 Definition of terms

In the following, any liquid to be pumped will only be called "**medium**". This operating manual is valid for the pump series

5G13...
5G21...
5G35...

For a better overview, **5G13...**, **5G21...** and **5G35...** referred to as **5GXX**.

The **5GXX pump series** are available in the following versions (pump body).

- Motor version consists of pump head, magnetic coupling, motor flange and motor.
- ZK version consists of pump head, magnetic coupling and motor flange.
- MK version consists of pump head and magnetic coupling.
- PK version consists of pump head.

You can find the exact design of your pump in the respective order documentation.

1.5 Representations abroad

A list of our worldwide representatives with respective addresses can be requested from the manufacturer's factory, or on the Internet at www.scherzinger.de .

Most of the agencies are sales branches, some of which also carry out repair and maintenance work. However, these are preferably carried out at the main plant in Furtwangen.

1.6 Symbolism in this manual

1.6.1 Hazard warning levels

Marking of instructions in the operating instructions. The safety instructions contained in these operating instructions, which may cause a hazard if not observed, are specially marked:



If disregarded, there is a danger to people.



If disregarded, there is a risk of electrical voltage.



These instructions must be taken into account for explosion protection in accordance with Directive 2014/34/EU ("ATEX Directive").

ATTENTION

If disregarded, there is a danger to the machine.

Instructions attached directly to the pump such as

- Name Plate
- Direction of rotation arrow
- Marking of the connections

must be observed and kept in legible condition.



Texts marked with this symbol contain very important hints!

Be sure to pay attention to these texts!



This icon indicates texts that contain important hints/comments or tips.

1.6.2 Specific Hazard Symbols



Warning of dangerously hot surfaces!



Warning against mechanical movements or hand injuries!

1.6.3 Common Symbols

- This item indicates the description of the activities you are supposed to perform.
 - This line indicates bullet lists.
If cross-references to other chapters are required within the text, the spelling is shortened for clarity, e.g.: [\(Representations abroad\)](#)
- (3) Figures in brackets refer to items in figures.

1.7 Personal protective equipment

The requirements for personal protective equipment resulting from the environmental conditions at the place of use, the pumped medium, from other products or from the combination with other products are not described in this operating manual and must be carried out by the operator according to the actual risks.

1.8 Definition of skilled workers / authorized personnel

Unqualified interventions in the product (pump) can result in physical damage or property damage. Only qualified personnel are therefore allowed to operate, put into and take out of operation, clean and maintain the product (pump).

Qualified personnel in this sense are people who:

- are familiar with the safety concepts of the product (pump).
- are instructed as operating personnel in the handling of the product (pump) and are familiar with the content of the operating instructions relating to operation and operation.
- have received appropriate instruction from qualified personnel.
- on the basis of their training, experience and instruction as well as their knowledge of relevant standards, regulations, accident prevention regulations, explosion protection and operating conditions, have been authorized by the person responsible for the safety of the product (pump) to carry out the necessary activities in each case and to be able to identify and avoid possible hazards.

1.9 *Obligation of the operator*

The operator undertakes to only allow skilled workers to work with this product (pump) who:

- have been sufficiently trained in accordance with the activities to be performed.
- Familiarized with the basic regulations on occupational safety, explosion protection and accident prevention and instructed by qualified personnel in the handling of the product (pump).
- have read and understood the safety and warning instructions in the operating instructions.

In the interest of all parties involved, please follow the following instructions:

- Supplement the operating instructions with generally applicable, statutory and other binding regulations on occupational safety, accident prevention and environmental protection as well as explosion protection and instruct the personnel involved in the product (pump) in it!
- Supplement the operating instructions with instructions on how to consider operational specifics, e.g. about work organization, work processes, personnel deployed (including supervision and reporting obligations)!
- Clearly define the responsibilities of the staff for operating, cleaning, maintaining, etc.!
- Check the safety and hazard-conscious work of the staff at regular intervals!
- Take measures to ensure that the product (pump) is only operated in a safe, functional condition!
- Have the product (pump) cleaned and serviced at the specified intervals. [\(Maintenance / Cleanen\)](#)
- Do not have any structural changes (except those described in the operating instructions) carried out without the written permission of the manufacturer.
- Rule that people who have not been instructed in the residual risks when working on and with the product (pump) with the help of the safety instructions are not allowed to enter the danger area of the product (pump)!
- At surface temperatures above 50 °C (122 °F), a warning sign must be clearly visible on the machine. At surface temperatures above 80° C (176°F), insulation must be installed, or the area must be fenced/demarcated at a sufficient distance from the source of hazard.
- Securing the working environment is the sole responsibility of the operator.

1.10 Obligation of the staff

All people who are tasked with working on the product (pump) are obliged to

- Observe the basic regulations on occupational safety and accident prevention.
- Read the safety and warning statements in this documentation.

In the interest of all parties involved, please follow the following instructions:

- Refrain from any safety-questioning way of working!
- Observe all hazards and warnings in this operating manual!
- In addition to these operating instructions, please observe generally applicable, statutory and other binding regulations on occupational safety and accident prevention, explosion protection and environmental protection!
- Take note of the fire detection and firefighting options and find out about the location and operation of fire extinguishers!
- Wear appropriate protective equipment according to the work to be done!
- Don't wear loose long hair, loose clothing, or jewelry (including rings)!
- Only carry out work for which you have been sufficiently trained!
- Do not carry out any repair work without prior consultation with the manufacturer and the operator!
- Do not carry out any structural changes without the written permission of the manufacturer (except those described in this operating manual)!
- Make sure that other people who are not working on the pump (and therefore not aware of the risks that can arise when handling the pump) cannot enter the hazardous areas.
- If a safety hazard occurs, put the pump out of operation! Secure them against recommissioning and inform the operator immediately!



1.11 Marking using the example of the pump type 5G21SPSPMMAL/M.N8A#5GM-ID8

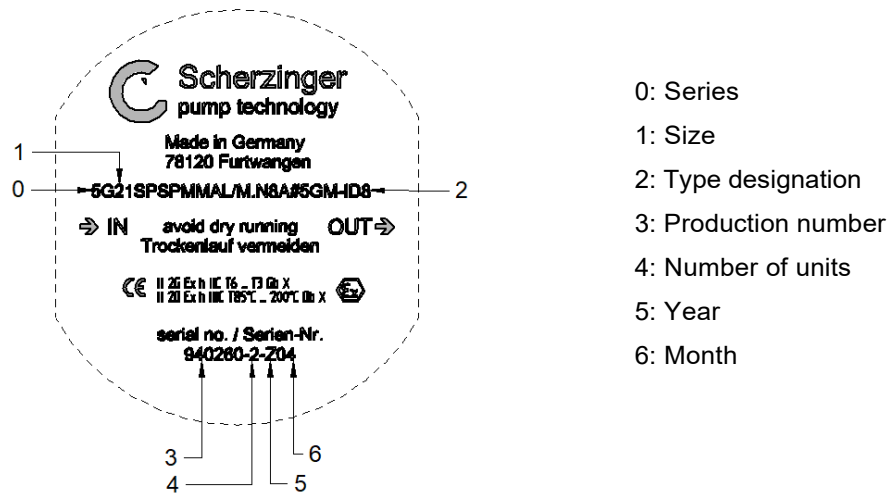

Fig. 1: Nameplate for pump with motor

Device Group	II	Operations above ground
Category	2	High security
Zones	1 and 21 2 and 22	high level of protection extended level of protection
Atmosphere	G	Gas
	D	Dust
Level of protection	Ex h	High level of protection Constructive safety Ignition protection type "c"
Group	IIC	Gas group
	IIIC	conductive dust
Temperature class	T6... T3 T85°C... 200°C	Surface temperature dependent from the pumped medium
Device protection level	Gb	Gas
	db	Dust
Explosion group temperature class	X	Not applicable. Follow the instructions in the operating manual.*

* The temperature class(es) on the device may only be specified if the resulting surface temperature is determined by the device itself (according to DIN EN 80079-36), i.e. in the case of pumps, the temperature of the surfaces is determined by the pumped medium during normal operation.

1.12 Intended use / normal operation

The product (pump) defined in the technical data is only suitable for pumping low- to medium-viscosity, particle-free, degreasing to well-lubricating media that have no corrosive or aggressive influence on the material of the product (pump). It is suitable for conveying both alkaline and acidic media.

The product (pump) is exclusively

- for commercial use,
- for the promotion of media,
- intended for use by authorized personnel, from a minimum age of 16 years.

Sufficient knowledge of an official language is required for the operator, the operating personnel as well as the maintenance and repair personnel.

The product (pump) has not been designed for use in radioactive or biologically contaminated atmospheres and corresponding media!

Only spare / wear parts that have been approved by the manufacturer may be used.

1.12.1 Limit values

The intended use can be ensured by complying with the following limit values:

Description	Value
Max. differential pressure increase	max. 20 bar depending on material combination and medium
Max. system pressure (pressure side)	180 bar depending on material combination and medium
Max. suction vacuum	0.9 bar (filled with medium)
Operating temperature	-20 to 130 °C
Ambient temperature	-40 to 60 °C depending on the materials and attachments
Viscosity range	0.5 to 10,000 mm ² /s
Speed range	0 to 1800 1/min
Sound pressure level	< 80 dB(A) measured at: Speed: 1500 1/min Operating pressure: 10 bar Operating temperature: 20 °C Pumped medium: 1 mm ² /s, non-lubricating (Sound pressure level)
Dimensions	please refer to the corresponding data sheets (Technical data)
Add-on parts	see applicable/supplied documents (engine, PT100, etc.)
Electrical parameters	see applicable/supplied documents (engine, PT100, etc.)
Max. torque of the clutch	14 Nm

The listed limit values are only guideline values. The actual limits depend on the use case. Influencing factors are, for example, the viscosity and the type of medium to be pumped.

Due to the versatile combination possibilities, regarding the different sizes, gears, motor speeds and electrical parameters, a clear and clear representation of normal operation for all pumps is not possible in the respective variants. In this case, reference is made to the respective order documentation.

Any other and further use/use, as described in the operating instructions, is considered not to be in accordance with the intended purpose.

1.12.2 Temperature classes and permissible temperatures

Temperature class		Shutdown temperature when Tmax of the magnetic coupling is reached	Shutdown temperature when Tmax of the pumped medium is reached	Shutdown temperature when Tmax of the pump surface at the containment shell is reached
T3 ^{*1}	200°C	150°C*	150°C*	150°C*
T4 ^{*1}	135°C	85°C	85°C	85°C
T5	100°C	50°C	50°C	50°C
T6	85°C	35°C	35°C	35°C

* Due to the magnetic material NdFeB, the design-related shutdown temperature is +150°C

*¹ Operation with media temperatures above 130°C for PEEK gears is not permitted due to design

1.12.3 Series Overview / Wetted Parts

Case [1], [2], [11], [12]	1.4404
Waves [3], [4]	1.4571 1.4571/Cr2O3
Gears [5], [6]	PEEK Nitronic 60 (N6) Waukesha 88 (W8) 1.4528 hardened (SS)
Warehouse [20]	SSiC PEEK
Magnetic clutch hub [8], [31], [32]	1.4571
Gaskets [29], [30],	PTFE FFKM Inconel 718
Pumped medium	Note the resistance to the above-mentioned materials listed.

1.12.4 **Design Printing and Design Temperature (MAWP and MAWT)**

High Pressure Pump 5GXX

Limit values	Gasket
MAWP = 225 bar @ MAWT = -40°C to +20°C	PTFE or FFKM
MAWP = 180 bar @ MAWT = up to +100°C	PTFE or FFKM
MAWP = 169 bar @ MAWT = up to +180°C	FFKM
MAWP = 135 bar @ MAWT = up to +250°C	FFKM, if applicable. Inconel 718
MAWP = 112 bar @ MAWT = up to +400°C	Inconel 718
MAWP = 65 bar @ MAWT = up to +500°C	Inconel 718

1.12.5 **Painting**

All pumps are delivered at the factory without an external painting/coating.

1.12.6 **Maximum possible speed**

The maximum possible speed depends on the pump size and the media viscosity:

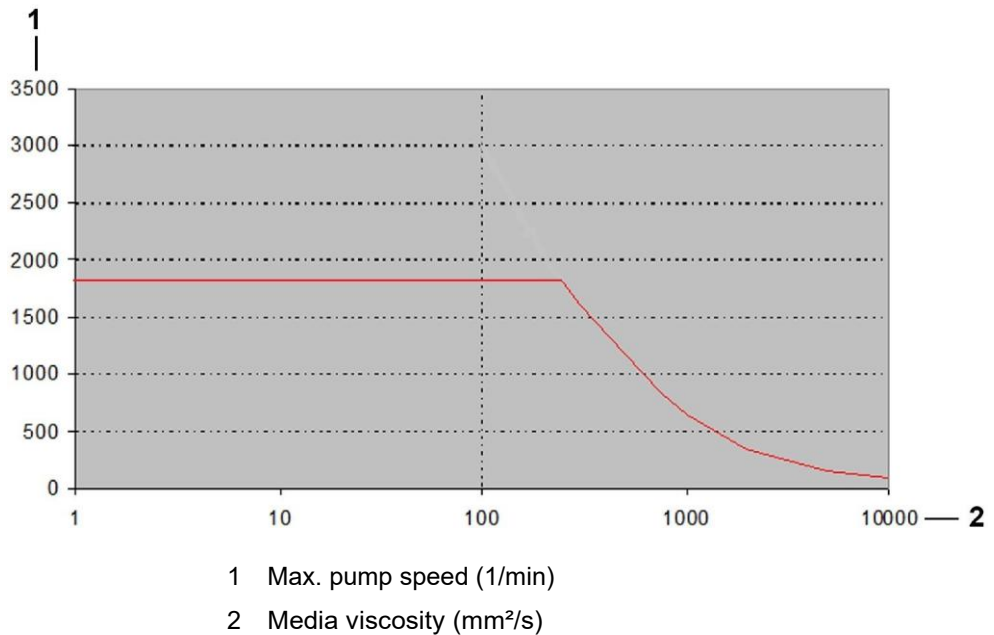

Fig. 2: Viscosity range



If one or more of the limit values described in this section are exceeded, it is imperative to ask the manufacturer's factory whether these operating conditions have been approved by the manufacturer. Otherwise, a modification of the pump must be carried out to your use case, otherwise the pump or the system in which the pump is integrated can be damaged or destroyed, posing a risk to personnel.

1.13 Improper use / interference

Deviations from normal operation are to be defined as disturbances.

Foreseeable disruptions can be defined as follows:

- Partial or complete dry running (caused by e.g. closed fittings, clogged filters ...)
- Larger foreign substances in the medium (>50µm) (e.g. welding beads, deposits from containers, sediments, sealing materials (e.g. Teflon tape) ...)
- Wrong direction of rotation
- Pressure overload (caused by e.g. closed fittings, defective components ...)

When the pump is operated (with magnetic coupling), there must be no ferritic components in the medium.

1.13.1 Hazard from dust



When the pump is operated in a dust atmosphere, there is a possibility of dust deposition on the surface of the pump. This can result in limited heat dissipation and smoldering nests can form.

- Regularly remove dust deposits from the surface of the pump

1.13.2 Hazard due to dry running of the pump



Static charge is possible when the pump runs dry.

- The interior of the pump, containment shell and suction and discharge line must always be completely filled with pumped medium during operation.
- When starting and shutting down the pump, the operator must ensure that the pump is always completely filled with the pumped medium.
- Dry-running monitoring for use in category 2, e.g. by level monitoring, flow measurement

1.13.3 Hazard of overheating the pump



With longer opening hours of the pressure relief valve, the media temperature can rise quickly, as the medium is only pumped in a circuit.

- If the pump is designed with a pressure relief valve, temperature monitoring must be installed on the operator's side
- A temperature monitoring system (ignition protection type b1) must be installed

1.13.4 **Danger from overpressure**



In the event of malfunctions, pumping against closed components like fittings, valves, filters etc. may occur. This leads to high temperatures in the pump after a short time.

Measurements have shown a temperature input of 80K within 4 minutes (speed 1500 1/min, opening pressure 7 bar, sealed pressure pipe).

In these operating conditions, the surface temperature must be monitored. The pump must be switched off at least 50K below the maximum permissible surface temperature, as the surface temperature may continue to rise with a delay after shutdown.

The following diagram shows the increase in the pump surface temperature with the pressure line closed and permanent circulation via the internal pressure relief valve. The media temperature at the beginning of the measurement was ambient temperature (20°C).

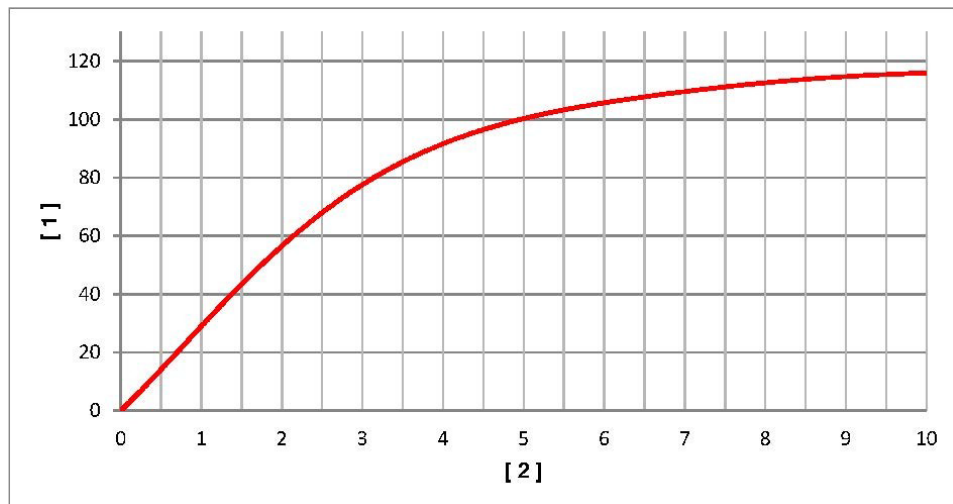

- 1 Surface Temperature Rise (K)
- 2 Time (min)

Fig. 3: Temperature increase

Note: If the ambient temperature is above the media temperature, the surface temperature increase can be even higher!

1.13.5 **Hazard from particles/foreign substances in the medium**

If the presence of foreign substances in the pumped medium cannot be reliably ruled out, measures must be taken to prevent foreign substances from entering the pump chamber.

- Filter with Contamination Indicator
- Filter with underpressure or differential pressure monitoring

1.13.6 **Hazard from operating at too high a speed**



If the maximum permissible speed is exceeded, there is a risk of excessive heating of the pump. If the maximum speed cannot be reliably maintained, monitoring must be carried out.

1.13.7 **Exposure to electricity**



If there is insufficient or no equipotential bonding, there is a risk of static charge and sparking due to tuft discharge.

- All attachments must be electrically conductive.
- Pipelines and product connections must be grounded separately.
- Pump must be grounded via drive motor or position agreed with the customer.
- Check all ground connections regularly for tightness.

The pumps are delivered unpainted at the factory. If the surface is to be painted afterwards, the subsequent paint thicknesses must be considered to avoid tuft discharges.

- Explosion class IIA and IIB: max. 2 mm
- Explosion class IIC: max. 0.2 mm

1.13.8 **Danger from exceeding the maximum Torque**



If the resistance in the pump is too high (e.g. due to too high viscosity of the medium or solids in the medium), the torque at the coupling increases. This can lead to the magnetic field breaking off and strong heat generation at the clutch. If necessary, the temperature at the coupling must be monitored.

- Temperature monitoring system (ignition protection type b1) must be installed. See also operating instructions of the coupling.

1.13.9 **Hazard from mechanically generated sparks**



In the event of mechanical damage, noise is generated at the pump. If excessive noise occurs, the pump must be switched off immediately, otherwise sparks may form and heat may be generated at the pump.

1.14 The complaint

Claims for damages relating to transport damage can only be asserted if the manufacturer and the delivery company are notified immediately.

For returns (due to transport damage / repairs), prepare a damage report immediately and return the parts, if possible, in the original packaging, to the manufacturer's factory.

- When accepting the goods, note any transport damage on the freight documents!
- Enclose the following information with the return:
 - the name and address of the sender and the recipient,
 - type and serial number of the product (pump),
 - Description of the defect,
 - In the event of transport damage: name of the delivery company and, if possible, delivery time, name of the driver and police registration number of the delivery vehicle,
 - Declaration of non-objection.

1.15 Warranty and liability

For the use of the product (pump), our **General Terms and Conditions of Sale and Delivery apply**.

Deviating agreements must be recorded in writing and confirmed by us!

The General Terms and Conditions of Sale and Delivery are handed over to the Operator with the offer.

Warranty and liability claim for personal injury and property damage are excluded if they are due to one or more of the following causes:

- improper use of the product (pump).
- Operation of the product (pump) in the event of defective safety devices or improperly installed or non-functional protective devices and / or safety devices.
- Failure to observe the instructions in this operating manual regarding safety, transport, storage, assembly, commissioning, operation, maintenance and repair of the product (pump).
- improper assembly, commissioning, operation, maintenance and repair of the product (pump).
- Poor monitoring and maintenance of parts that are subject to wear and tear.
- unauthorized structural changes to the product (pump).
- Catastrophes due to the impact of foreign bodies and force majeure.

Only original spare parts from the manufacturer may be used so that functional reliability can be guaranteed.

1.16 Declaration of Conformity

1.16.1 Declaration of conformity according to Directive 2014/34/EU

Declaration of Conformity according to Directive 2014/34/EU (ATEX)

Within the meaning of EC Directive 2014/34/EU of 26 February 2014 and the legislation adopted to implement it, the manufacturer declares:

Scherzinger Pumpen GmbH & Co. KG
Bregstraße 23 - 25
78120 Furtwangen / Deutschland

that the explosion-proof, exported product described in the operating and safety instructions:

Pump
5G13...
5G21...
5G35...

is a device within the meaning of Article 1, (1) a) of Directive 2014/34/EU and meets the essential health and safety requirements set out in Annex II to Directive 2014/34/EU and the harmonized directives set out below:

DIN EN ISO 80079-36:2016-12

DIN EN ISO 80079-37:2016-12

DIN EN 1127-1:2019

The pump type mentioned corresponds to the ignition protection type constructive safety "c". An ignition hazard assessment is available. The pump bears the marking:



II 2G Ex h IIC T6 ... T3 Gb X

II 2D Ex h IIIC T85°C ... 200°C Db X

In accordance with Article 13, (1) b) ii) of Directive 2014/34/EU, in conjunction with Annex VIII, the technical documentation is deposited with a body notified by the European Commission.

The person responsible for documentation: Matthias Derse Furtwangen,

Monday, April 20, 2022



Dipl.-Ing., MBA Matthias Derse
CEO

1.16.2 Declaration of conformity according to Directive 2006/42/EC (Machinery Directives)

Declaration of Conformity in accordance with Directive 2006/42/EC

Within the meaning of EC Directive 2006/42/EC, Annex II A, of 17 May 2006, the manufacturer declares :

**Scherzinger Pumpen GmbH & Co. KG
Bregstraße 23 - 25
78120 Furtwangen / Deutschland**

that the product:

**Pump
5G13...
5G21...
5G35...**

is supplied with an electric propulsion machine and thus complies with the provisions of Directive 2006/42/EC, Annex I, No. 1.

The harmonized standards applied below:

**EN ISO 12100:2011
EN ISO 13857:2020
EN ISO 13732-1:2008
EN 809:1998+A1:2009 +
AC:2010 EN 60204-1:2019**

Guidelines applied below:

**2006/42/EC Machinery Directive
2014/30/EU Electromagnetic Compatibility (EMC Directive)
2014/34/EU Explosion Protection Directive (ATEX)**

Applied national technical standards and specifications:

Accident prevention regulations

The person responsible for documentation: Matthias Derse Furtwangen,
Monday, April 20, 2022



Dipl.-Ing., MBA Matthias Derse
CEO

1.16.3 **Notes on CE conformity regarding the installation of an engine / Propulsion**

Note on CE conformity according to 2014/34/EU (ATEX Directive) and 2006/42/EC (Machinery Directive) of pumps/motor units when the motor/drive is installed by the customer (dealer/operator)

We hereby confirm the CE conformity of our pump unit, provided that the following criteria are met with regard to the intended use, as described in the operating instructions:

- The drive meets sufficient performance and design data in relation to the required flow rate and pressure
- The engine is only mounted with the corresponding intermediate flange supplied by Scherzinger and the matching coupling. These parts must not be reworked.
- The flange and motor shaft dimension required for the specified motor size is fulfilled
- The installation must have been carried out professionally, in accordance with the Scherzinger operating instructions
- The correct use of an explosion-proof drive with regard to the required ignition protection, dust and water protection (IP), speed (number of poles) and connection values. Operation with a frequency converter is only permitted within the scope of the possibilities described in the operating instructions.
- Engine conformity according to machine guidelines of the current state of the art
- Ensuring grounding
- Pump may be painted in compliance with [\(painting\)](#) .

Anyone who, as a reseller or dealer, connects the pump to a motor unit and places it on the market together as a single unit, must fully comply with the requirements of 2014/34/EU, in particular Article 13 (Conformity assessment procedure). In this case, the reseller or dealer himself becomes the manufacturer.

The company (operator) is responsible for the overall conformity of the pump/motor unit, within the meaning of the Industrial Safety Ordinance (BetrSichV), which carries out the assembly or assembly itself and commissions the device.

Furtwangen, Montag, 20. April 2022



Dipl.-Ing., MBA Matthias
Derse Managing Director

1.17 Declaration of Non-Objection

The pump and its accessories submitted by us for inspection or repair together with this clearance certificate,

Type	Pump Number	Delivery date
------	-------------	---------------

Operating data:

_____ (°C)	_____ (mm ² /s)	_____ (cash)	_____
Temperature:	Viscosity:	Printing:	Medium:

Reason for the repair order

Reason (continued)

- has not been used with fluids that are hazardous to health
- encountered fluids subject to labelling or containing pollutants.

Specify the last production medium

The pump has been carefully emptied and cleaned outside and inside before shipping/provision. The cleaning steps were carried out according to the corresponding operating instructions.

- Special safety precautions are not required for further handling.
- The following safety precautions are required regarding flushing media and disposal:

We assure you that the above information is correct and complete and that the shipment is carried out in accordance with the legal provisions.

Company	Name
Road	Position
City	Phone
Country	Fax
Date	Company stamp / signature

Pumps delivered without this complete safety data sheet cannot be inspected or repaired for safety reasons.

2 Safety instructions

The pump is a quality product manufactured according to the recognized rules of technology and has left the manufacturer's factory in perfect condition in terms of safety!

Nevertheless, there are:

- during assembly / disassembly,
- during commissioning / decommissioning,
- during operation and
- during maintenance / cleaning residual risks.

In the case of

- ignorance of these residual risks,
- Failure to comply with the warnings in these operating instructions,
- improperly performed work,
- improper use of the pump

these residual risks can lead to death, serious injuries to persons or property damage!

Due to these latent residual risks, the manufacturer is obliged to inform the operator and the user about these risks!

We - the manufacturer - comply with this obligation to instruct with the descriptions in this operating manual in general and with this chapter in particular.

2.1 Hazard from hot components

If the pump is operated in a closed housing, it must be ensured that it does not overheat!



- For automatic monitoring, we recommend installing a temperature sensor.
- If there is danger from hot components, you must secure them with on-site protection against contact.

2.2 Danger from electric shock



If live components are touched, there is a risk of life-threatening electric shock!

Work on electrical equipment parts or equipment may only be carried out by an authorized electrician in accordance with the electrotechnical rules!

Access to the electrical control cabinet is only permitted to authorize qualified personnel. Covers of live parts must not be removed!



In the event of faults in the electrical power supply, switch off the pump immediately or disconnect the pump from the power supply!

- Check the electrical equipment of the pump regularly! In case of damage to the electrical equipment, switch off the pump immediately! Have loose connections or scorched / damaged cables replaced immediately!
- If there is an imminent risk of electric shock, switch off the pump!

- Secure the pump against recommissioning.

Five safety rules before starting work:

- Unlock
- Secure against re-switching
- Determine the absence of voltage
- Grounding and shorting
- Cover or block off adjacent live parts

2.3 Hazard from magnetic fields

The magnetic coupling contains permanent magnets. The magnetic field can pose a risk to people with active or passive implants!



People with pacemakers, active or passive implants must not be in the magnetic field. A safety distance of 25 cm from unassembled individual parts of the couplings must be maintained. For mounted couplings with axially aligned magnetic rotors and surrounding coupling housing (pump carrier), a minimum safety distance of 10 cm applies.

- When working on the pump, it is forbidden to wear ferromagnetic jewelry (such as rings, chains, etc.) or other magnetizable objects!
- Do not bring electronic data carriers or devices into the area of influence of the magnetic field.
- Do not place ferromagnetic tools on the axes or near the permanent magnetic field.
- Make sure that no ferromagnetic objects are attracted to the magnetic coupling and that they have a safety distance of at least 15 cm.

2.4 Exposure to pumped media



When handling hazardous media (e.g. hot, flammable, explosive, toxic, hazardous to health), observe safety regulations for handling hazardous substances

- Personal protective equipment must be worn when working on the pump.

2.5 Hazard due to pump weight



- Risk of crashing and bumping during lifting and transport!
- Due to the weight of the pump, there is an increased risk of injury during transport.
- Transport may only be carried out by trained personnel.
- The minimum load capacity of the lifting equipment must always be greater than the weight of the component to be lifted. Weight see data sheet for the pump.

2.6 Information on explosion protection

The information on explosion protection listed in this chapter must be observed when operating in potentially explosive atmospheres.

In addition to these tips, further information on explosion protection may be found in the respective chapters.

Supplement for intended use

When the pump is used in potentially explosive atmospheres, it may only be operated in compliance with the limits of the Ex marking on the product. See chap. 2.x (Ex marking).

All work on the pump, such as installation, commissioning, maintenance and troubleshooting, must ensure that it is carried out in an explosion-free environment.

The operator must ensure that the pump is completely filled with the pumped medium at all times (in normal operation) so that no explosive atmosphere can form.

Supplement to improper use

When the pump is used in potentially explosive atmospheres, the following points are contrary to the intended purpose:

- Pumping of media with particles larger than 50 µm, see also chap. 1.13
- Operate the pump against closed fittings, see also chap. 1.13
- Operation of the pump with a damaged clutch cover
- Operation of the pump without safety devices
- Carrying out work on the pump in potentially explosive atmospheres

2.6.1 Target group

- There is an increased risk of injury for people who carry out work for which they have not been qualified or instructed.
- All work on the pump may only be carried out by people who are familiar with it, who are informed about the hazards in potentially explosive atmospheres and who have the necessary qualifications.

2.6.2 Safety devices

The pump can be equipped with the following safety devices:

- Connection points for temperature monitoring on the containment shell or pump head

Temperature monitoring and limiting system (ignition protection type "b1") must be installed on the operator's side.

Existing safety equipment must not be damaged, altered, removed or put out of service.

In the event of damage or malfunctions, these must be replaced immediately.

The proper functioning of the safety devices must be checked at regular intervals by qualified personnel.

Note: Safety equipment must be inspected after completion of maintenance, servicing and repair work.

2.6.3 Ignition hazards and protective measures

Potential ignition source	Cause	Protective measures
Hot surface	Heating of the housing wall by heat dissipation in normal operation and media temperature up to 150 °C	<ul style="list-style-type: none"> ▪ The maximum surface temperature is set under the most unfavorable conditions ▪ Optional connection for temperature sensor in containment shell and pump head (for category 2)

		<ul style="list-style-type: none"> Temperature measurement of pumped medium must be carried out by the operator Temperature control and limitation system (ignition protection type "b1") Provision by operator
Hot surface	Lack of lubrication leads to overheating of the bearing	<ul style="list-style-type: none"> Optional connection for temperature sensor in camp lantern (for category 2) Temperature control and limitation system (ignition protection type "b1") Provision by operator
Mechanically generated sparks	Storage damage	No further measures necessary, as only Gb is required
Static Charge	Parts of non-metallic material with undetermined surface resistance	Conductive materials Potential differences can be dissipated via a marked terminal

2.6.4 Temperature limits

The following switch-off temperature limits must be observed. If the limit values cannot be reliably complied with operationally, temperature monitoring must be installed.

Temperature class		Shutdown temperature when Tmax of the magnetic coupling is reached	Shutdown temperature when Tmax of the pumped medium is reached	Shutdown temperature when Tmax of the pump surface at the containment shell is reached
T31	200°C	150°C ²	150°C ²	150°C ²
T41	135°C	85°C	85°C	85°C
T5	100°C	50°C	50°C	50°C
T6	85°C	35°C	35°C	35°C

1 Operation with media temperatures above 130°C is not permitted for PEEK gears due to its design.

2 Due to the use of the magnetic material NdFeB, the design-related shutdown temperature is +150°C.

2.6.5 Ex marking



Fig. 1: Ex marking gas



Fig. 2: Ex marking dust

1 CE mark

6 Ignition protection type

- | | |
|-------------------|---------------------|
| 2 Ex-Symbol | 7 Explosion group |
| 3 Device Group | 8 Temperature class |
| 4 Device Category | 9 EPL Marking |
| 5 Ex atmosphere | 10 More information |

Explanation

Device Group II	II = Equipment for use in industrial sectors other than mining
Device Category - /2G-/2D	No explosive atmosphere allowed inside the device, use in Zone 1, gas or dust
Ignition protection type	Ex h = type of protection (according to ISO 80079-37) c = Constructive safety
Explosion group IIC or IIIC	Permissible for substances of explosion group IIC (gas) or IIIC (dust)
Temperature class	T6 ... T3 / T85°C ... 200°C = max. surface temperature depending on the pumped medium The maximum permissible temperatures based on the respective pump design are determined according to the temperature limits table.
Gb/Db	Ex atmosphere: G = gas, D = dust High level of safety, approved in Zone 1
X	Reference to specific explosion protection information described in this manual.

3 Transport and interim storage

3.1 Shipment of the pump and protective measures

The pump is shipped at the factory in such a way that it is protected against shocks and shocks. Furthermore, inlets and outlets are closed with protective plugs.

This measure is necessary to prevent the leakage of residual liquid that is still in the pump head as a residue because of a test run.

This also protects the connection threads. Penetration of foreign bodies into the interior is reliably prevented.

After receiving the pump, you must immediately check the pump for damage in transit. If you notice any damage, it must be reported immediately to the responsible freight forwarder and Schertzinger Pumpen GmbH & Co. KG, 78120 Furtwangen / Germany.

3.2 Interim storage

When storage the pump, consider the following points:

- Do not store the pump in wet or damp rooms.
- Leave the protective plugs in or insert them.
- If the storage period is stored for more than six months, take corrosion protection measures for shiny metallic parts.
- The storage rooms must not contain any ozone-generating equipment, such as fluorescent light sources, mercury vapour lamps, high-voltage electrical equipment.
- Make sure that there is no condensation. The relative humidity must be below 65%.
- When storing the pump, make sure that the storage temperature does not fall below 5°C or does not exceed 50°C.

3.3 Preservation for storage after operation / flushing of the pump

Depending on the medium pumped, the pump must be prepared differently for storage. If no toxic or aggressive media has been pumped, flush the pump briefly with water at low speed without increasing the differential pressure.

- When pumping hazardous or aggressive media, clean the pump in such a way that any subsequent maintenance work can be carried out without endangering the health of the personnel.
- Flush the pump at medium speed with a neutralizing medium. Disassemble and clean parts that are not completely cleaned during the rinsing process by hand.
- If hardening media (e.g. paints) have been conveyed, complete disassembly and cleaning of the individual pump parts is necessary to ensure proper function when recommissioning.

- Carry out the cleaning with conventional cleaning agents ([Technical Data](#)).
- However, after installation, rinse the pump again with water at medium pump speed.
- Observe the regulations when handling substances that are hazardous to health!



There is a risk of chemical burns and explosion hazards in the event of reactions of the pumped medium with the detergent used. When rinsing the pump, the detergent must be adapted to the last medium pumped to rule out a dangerous chemical reaction between the pumped medium and the detergent.

3.4 Return to the factory

If you return the pump to the manufacturer's factory for repair or maintenance, you must complete and enclose the Declaration of Non-Objection. Repair processing is otherwise not possible!

4 Functionality / Description

4.1 Function of the pump

The pumping action of a gear pump is generated by the counter-rotating rotation of two gears in a pump housing.

The gears are attached to two shafts, which in turn are in the pump housing and lid. One of the two gears is driven by a shaft; the second gear is carried along via the gear engagement.

The opening tooth gaps create a negative pressure that sucks the medium into the pump and transports it further between the tooth gaps and the housing wall.

In the area where the gears interlock again, the medium is pressed out of the tooth gaps and into the outlet. In this way, the medium can also be pumped against overpressure.

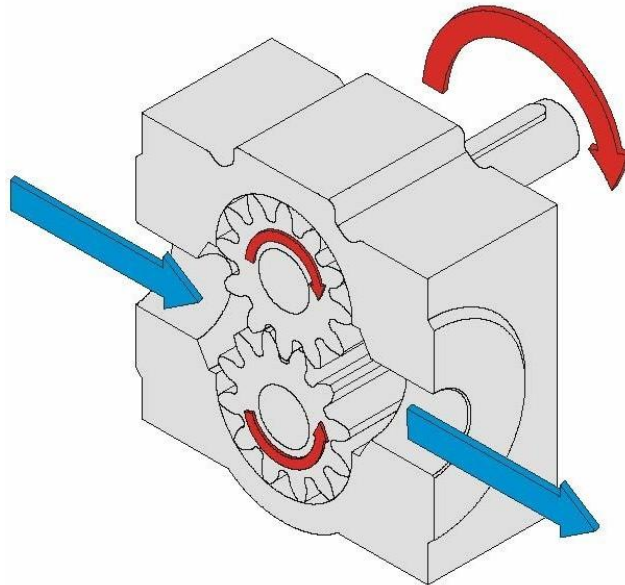
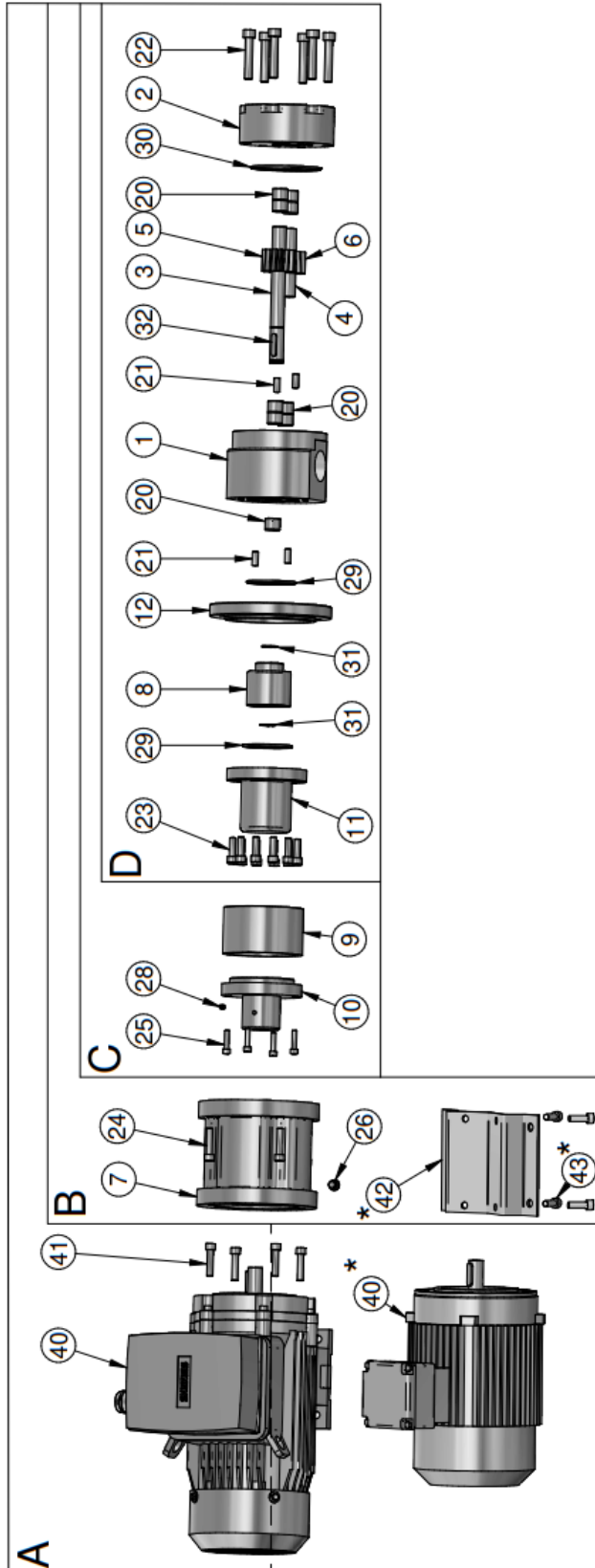

Fig. 4: Principle of operation of the gear pump

4.2 Structural design of the pump

4.2.1 Pump body



A: Engine version

B: ZK version

C: MK version

D: PK version

*Only for version with Bg80/IMB14 engine

The design of the pump head, consisting of two components, housing (1) and cover (2), enables simple, fast and economical maintenance and servicing.

The housing (1) and the lid (2) are screwed together with six screws (22). The exact position in relation to each other is determined by two cylindrical pins (21).

A sealing ring (30) is mounted between the housing and the lid.

The gears (5) and (6) attached to the shafts (3), (4) and (6) are axially fixed in the housing and cover. The shaft bearing in the housing and cover is provided by plain bearings (20). ([Bearing bushings](#)) The rotary motion from the drive unit to the pump is transmitted via a magnetic coupling (8) and (9) to the drive shaft (3) with drive gear (5).

Scherzinger pump heads of the 5GXX series are available in different sizes (size - to size -).

The theoretical funding data are:

Pump head	Vgth swallowing volums	Qth at 1400 rpm	Qth at 1800 1/min
5G13...	13.00 cm ³ /rev	18.20 l/min	23.40 l/min
5G21...	21.00 cm ³ /rev	29.40 l/min	37.80 l/min
5G35...	35.00 cm ³ /rev	49.00 l/min	63.00 l/min

It should be noted that during all maintenance work during which the pump is disassembled, all O-rings must be replaced during reassembly. Otherwise, absolute leakage safety is not guaranteed.

It is also important to keep the workplace absolutely clean, as dirt can jeopardize the proper functioning of the pump.

Assembly tool:

You will need the following tools:

- Hexagon screwdriver
- Flat-head screwdriver
- Ring wrenches or open-end wrenches
- Internal puller for bearing bushes
- Press-fit punches
- Torque Screwdriver

Disassembly:

- Turn off the pump and disconnect it from the supply.
- Remove the pump head from the drive unit ([assembly/disassembly of motor flange and drive unit](#))
- Place the pump head in front of you with the containment shell (11) facing upwards.
- Loosen and remove the eight cap screws (23).
- Remove the containment shell (11) upwards.
- Remove the O-ring (29) without damaging the O-ring seat.
- Remove the retaining ring (31) using snap ring pliers.
- Pull the magnetic clutch hub (8) upwards (attention: strong magnetism!).
- Remove the key (32) from the drive shaft (3).
- Remove the second retaining ring (31) using snap ring pliers.
- Remove the centering ring (12) upwards.
- Remove the O-ring (29) without damaging the O-ring seat.
- Place the pump head in front of you with the pump cover (2) facing up.
- Loosen and remove the six cap screws (22).
- Carefully pull off the pump cover (2).
- Remove the O-ring (30) without damaging the O-ring seat.
- Now you can remove drive shaft (3) with gear (5) and track shaft (4) with gear wheel (6).

Assembly:

- Hold the housing (1) with the gear chamber facing up.
- Insert the drive shaft (3) (longer shaft) into the continuous bearing seat of the housing (1) (longer shaft end downwards).
- Insert the running shaft (4) into the second bearing seat.
- Insert the new O-ring (30).
- Carefully insert the lid (2) onto the cylindrical pins (21).
- Insert the six cap screws (22) into the bore of the pump cover (2) and tighten them crosswise with 55 Nm.
- Turn the pump over. It is now in front of you with the free end of the wave facing upwards.
- Check if the pump rotates easily.
- Insert the new O-ring (29).
- Carefully insert the centering ring (12) onto the cylindrical pins (21).
- Attach the retaining ring (31) to the drive shaft (3) using snap ring pliers.
- Insert the key (32) into the drive shaft (3).
- Insert the magnetic clutch hub (8) onto the drive shaft (3). (**Attention:** strong magnetism!)
- Apply the second retaining ring (31) to the drive shaft (3) using snap ring pliers.
- Insert the new O-ring (29).
- Attach the containment shell (11) to the centering of the centering ring (12).
- Insert the eight cap screws (23) into the holes of the containment shell (11).
- Screw in all eight cap screws (23) and tighten them crosswise at 8 Nm.

4.2.2 Magnetic coupling

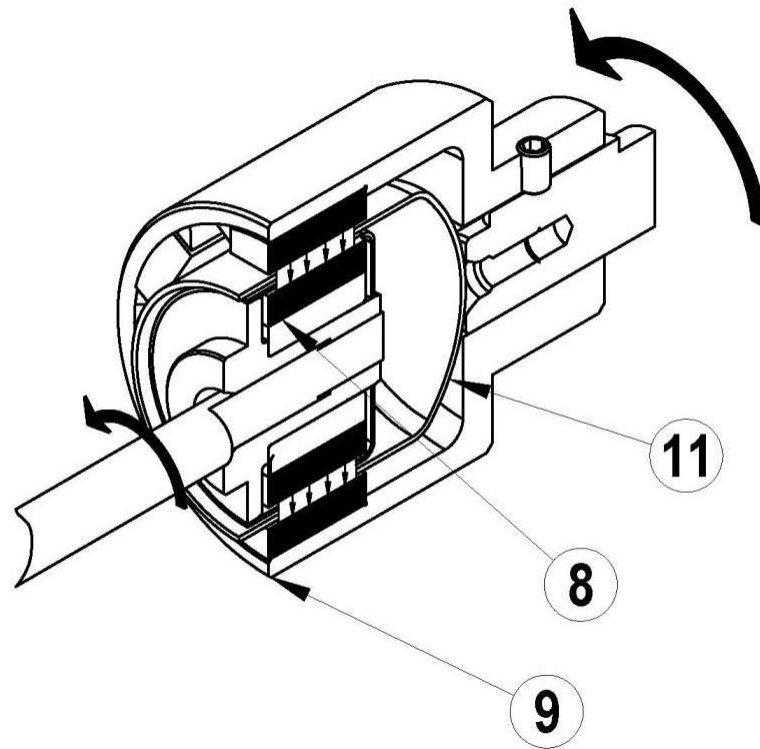

Fig. 8: Magnetic coupling

(The vertical arrows indicate the direction of the magnetic field. The curved arrows show the direction of rotation.)

With the magnetic coupling, the pump head is hermetically sealed, i.e. there is no need to guide a rotating shaft end to the outside. Leakage due to wear is therefore no longer possible, as only static sealing is done with O-rings.

The torque is transmitted to the magnetic clutch hub (8) by magnets in the magnetic clutch bell (9), which are magnetized alternately on the inner circumference, through a partition wall (containment shell (11)). Magnets, alternately polarized on the outer circumference, are also arranged there.

As soon as the maximum transmittable torque is exceeded, the magnetic field breaks off and the drive continues to run; the system begins to rattle uniformly, and the medium is no longer conveyed.

To re-engage the clutch, the pump must be stopped completely and restarted.

Operating times of more than 2 minutes when disengaged lead to a strong heating of the clutch. The magnets can be demagnetized: The torque to be transmitted and thus the achievable pressure increase is reduced. Avoid operating in this condition.

4.2.3 Bearing bushes

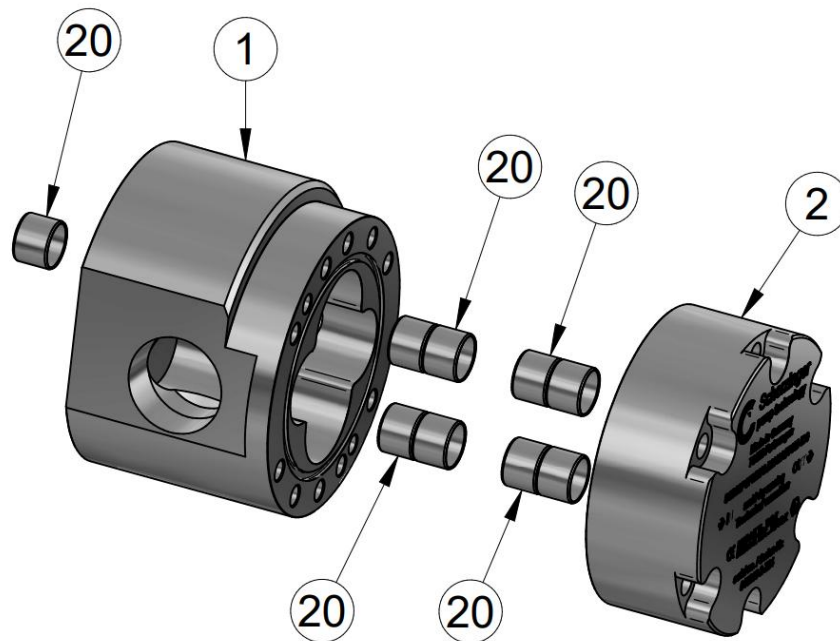

Fig. 9: Shaft bearings

Disassembly

The pumps must be sent to Scherzinger for replacement of the bearing bushings, as damage can easily occur during replacement. The replacement of the bearing bushings by the customer is possible with PEEK bearing bushings, but warranty and liability claims, including personal injury and property damage, are expressly excluded. SSiC bearing bushes are not replaceable by the customer, as the most precise manufacturing tolerances must be adhered to during the press-fit process to be able to guarantee trouble-free functioning.

Disassemble the pump as described in [\(Pump Body\)](#).

- Drag with a Inner-Puller carefully the four PEEK bearing bushes (20) out of the cover (2).
- Using the internal puller, carefully pull out the five PEEK bearing bushings (20) of the housing (1) from both sides.

When pulling off, do not damage the bearing seat or the sealing surfaces of the pump head. Care must be taken to ensure that only qualified personnel replace the bearing bushings.

Re-assembly

- Press the four new PEEK bearing bushes (20) with the centering attachment in front of the lid with a press-fit punch 0.5 mm backwards.
- Press in the five new PEEK bushings (20) of the housing (1) as explained in the previous step.
- Install the pump as described (pump body).

5 Installation / Assembly / Disassembly



Due to a design-related, shifted center of gravity of the pump, it can happen that the pump unit tilts during assembly.

5.1 Additional information when using the pump in a potentially explosive environment



Connection of the pipelines

The following points must be ensured when connecting the pipelines:

- Install cables for pumped media without tension.

Connection of sensors

To ensure the function and compliance with the maximum temperatures, the operator must take appropriate measures for measurement.

Safety-related level or temperature monitoring and limitation system (ignition protection type "b1").

The operator must ensure that the monitoring equipment provided for the pump corresponds to the category and temperature class in the respective zone.

Grounding and equipotential bonding



Fig. 3: Grounding symbol

If there is no equipotential bonding connection on the pump, a metallic connection with the drive motor must be ensured.

Ground the pump unit in the designated places.

The places are marked with earthing symbols.

Ensure equipotential bonding on pipelines when there is no conductive connection.

Connecting the motor

The operator must ensure that the electric motors provided for the pump correspond to the category and temperature class in the respective zone.

Connect the electric motor according to the manufacturer's instructions.

5.2 *Information on the location*

- First, carry out a visual inspection of the pump supplied by us for transport damage ([complaints](#))
- Then check whether a suitable pump type is available according to the following points:
 - Model type and design
 - Direction of rotation or position of the suction / pressure side
 - Temperature range

If you notice any differences between the pump design required in your system and the one we supply, please contact us immediately.

5.3 *Installation position*

Note that the pump unit is designed for horizontal installation only. In exceptional cases, the pump unit can also be installed vertically. It should be noted that the drive unit is located above the pump. In this case, increased noise emissions must be expected.

Screw the pump/pump units only to the foot provided for this purpose. The installation space must be level. Level out unevenness near the mounting points with suitable underlays so that a level is created over these four support points. If strong oscillations / vibrations occur during the operation of the pump, please note the points listed in the fault table (chapter "Fault").

5.4 Mounting the magnetic coupling

Repairs as well as maintenance of the magnetic coupling may only be carried out by the manufacturer.

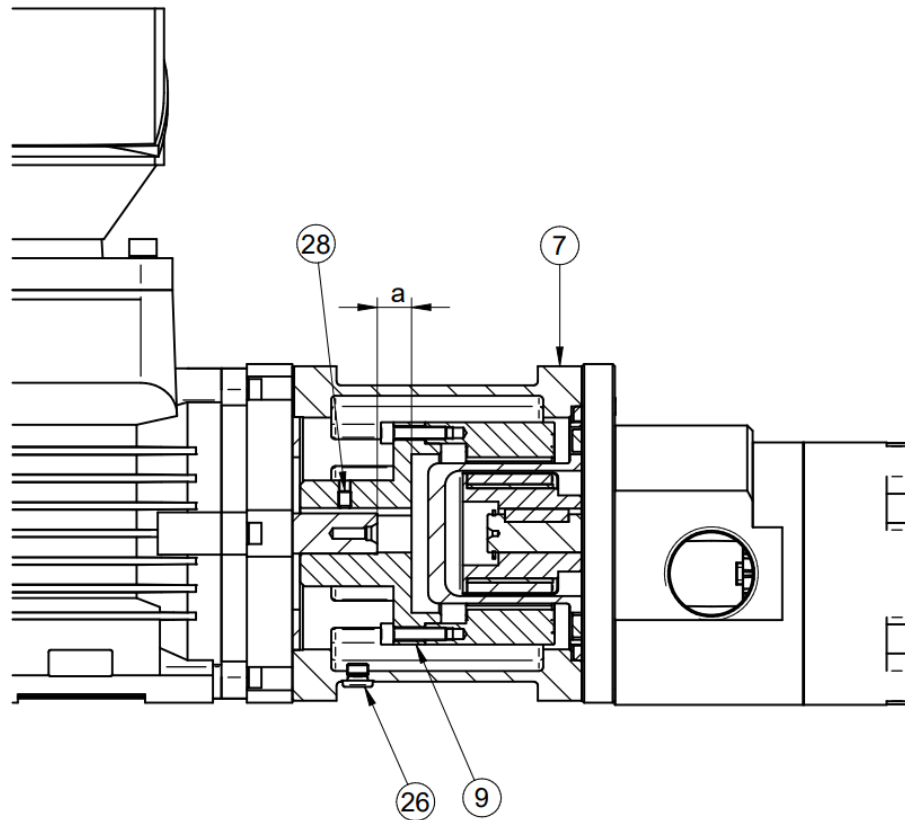

Fig. 10: Mounting the magnetic coupling

Slide the magnetic clutch bell (9) loosely onto the motor shaft until it stops. This procedure should result in the following measurements:

Engine size 80	16.2 mm
Engine size 90S, 90L	9.9 mm
Engine size 100, 112	2 mm

Then screw the magnetic coupling bell with the threaded pin (28) with a hexagonal screwdriver SW 3 mm with 9.5 Nm. Then attach the motor to the motor flange (7).

5.5 Assembly / disassembly of motor flange and drive unit

First, attach the magnetic coupling bell (9) and the motor flange (7) as described in [\(Mounting the Magnetic Coupling\)](#). Pay attention to the installation dimensions of the magnetic coupling.

The pump head is attached to the motor flange by means of the four fastening screws (24). Avoid attracting foreign objects to the magnetic coupling. Hold the pump head by the suction/discharge connections and insert it straight into the motor flange. Caution: Risk of injury due to entrapment of body parts. (Attention: strong magnetism).



WARNING Risk of crushing during pump assembly!

The pump can tip over if you are careless.

Secure the pump against twisting or tilting when mounting.

Furthermore, it should be noted that if a motor/drive is mounted on the pump by the customer, the CE/machine guidelines must be observed. To do this, the mounted motor/drive must meet the following criteria:

- Sufficient performance and design data related to the required flow rate and pressure
- Pump mounting only with the corresponding intermediate flange and flange diameter, as well as the specified motor sizes and the matching motor shaft dimensions
- Correct design for the required protection classes and environmental conditions such as IP and/or Ex
- Engine Conformity Machine Guidelines of the currently required standard

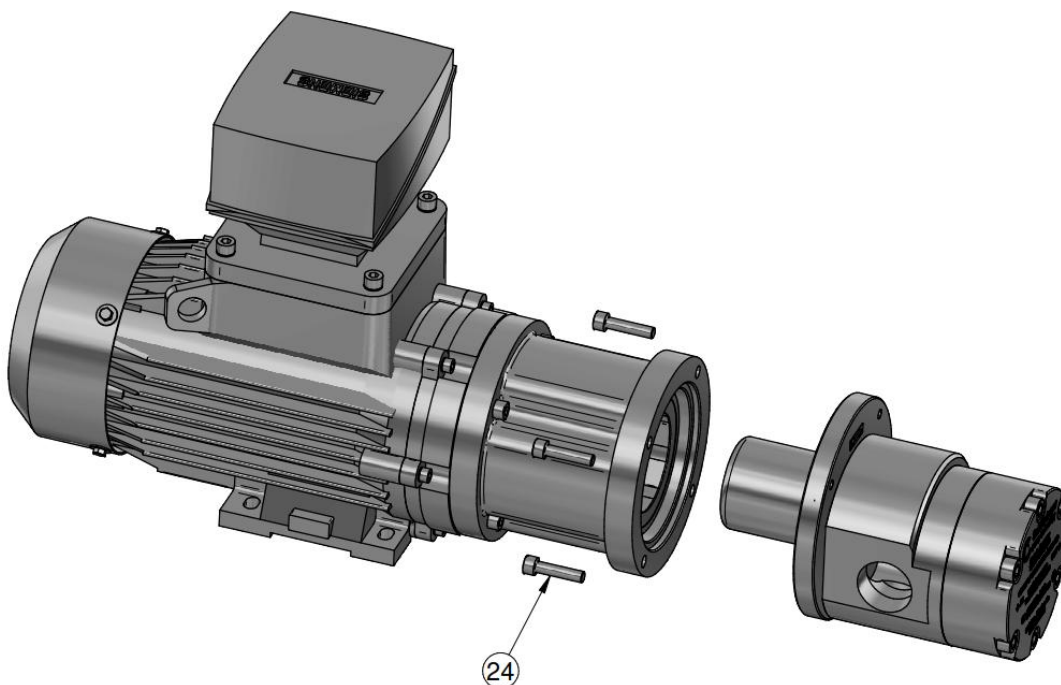

Fig. 11: Disassembly of pump head

Always carry out assembly work with the drive unit switched off.



Never install motor pumps in confined installation situations without sufficient ventilation, otherwise the motor will be poorly cooled and can overheat.

- Please also note the supplied engine operating instructions.
- Due to the variety of engines available, the drive will not be discussed in more detail at this point. Please note the enclosed motor documentation.
- Do not exceed the maximum permitted limit speed and the maximum permitted speed depending on the media viscosity.

5.6 Connecting cables



Before connecting the suction and discharge lines, check whether the connection flanges of the piping match those of the pump.

No forces or torques may be exerted on the pump via the connecting cables, and it may be necessary to support the connecting cables in front of the pump. Likewise, no forces caused by thermal expansion must act on the pump.

The connecting cables must be sufficiently dimensioned. They must not be smaller than the nominal diameter of the pump connections. On the suction side, we recommend a nominal diameter that is one step larger than the nominal diameter of the pump's suction connection.

The following are the following as a guideline for the maximum flow velocities in the pipes: Recommended flow velocities see table.

	up to 200 mPas	up to 600 mPas	up to 2000 mPas
Suction line	1.5 m/s	0.5 m/s	0.2 m/s
Pressure pipe	3.0 m/s	1.0 m/s	0.5 m/s



- Pre-connect a suction filter with at least 50µm filter fineness to avoid premature wear or destruction due to the ingress of foreign bodies that can lead to the destruction of the pump. Size it sufficiently large because of its internal resistance, otherwise it will affect the pump's absorbency.
- Make the necessary bends in the line with as large a radius as possible. Avoid pipe manifolds that bend as sharply as possible.
- Lay the suction line upwards towards the pump. If pipes must be laid rising and falling, provide ventilation at the highest points.
- After laying the pipes, check that the pipes are free of deposits, chips or similar contaminants, otherwise the pump may be damaged during commissioning.

Make sure that all pipes, fittings and screw connections are perfectly tight, otherwise gas may enter the pump on the suction side. The pump no longer primes. Medium can flow out on the print side.

If a suction height of 3 m is reached, we recommend installing a foot valve in the suction line. When the pump is switched off, the valve ensures that there is no media backflow through the pump or emptying of the suction line.

Please note that in this installation situation during the pump standstill, the pressure in the inlet becomes equal to the pressure in the outlet. For this purpose, please note the maximum system pressures ([limit values](#)).

Exemplary installation

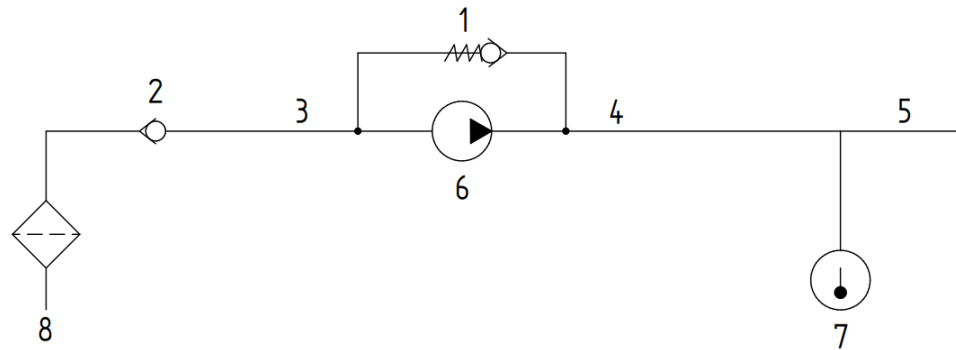

- 1: Pressure relief valve external
- 2: Check valve
- 3: Admission
- 4: Outlet
- 5: Pressure pipe
- 6: Pump
- 7: Temperature sensor
- 8: Filter

Fig. 12: Pipeline installation

6 Commissioning / Decommissioning

6.1 Additional information when using the pump in a potentially explosive environment



Measures before commissioning

- All dismantled guards must be installed before commissioning.
- If other components are installed for commissioning, it is essential to follow the respective operating instructions.
- The suction line must be tight and well vented.
- Only use the pump and attachments in their original condition.

Safety test for commissioning

Check the functions of the electrical equipment, especially those related to safety and protective measures.

- Level monitoring
- temperature monitoring: here the limit values from chap. 2.x "Observe temperature limits"

Filling the pump

Before switching on, the pump, suction line and pressure line must be filled with the pumped medium. The formation of air sacs must not be possible at any point in the system.

Starting the pump

The pump may only be started under the supervision of an appropriately qualified person.

6.2 Prerequisite for commissioning

Once fully assembled, check the pump and peripherals again using the following points:

- Can you turn the pump by hand (e.g. on the fan wheel of the motor)?
- Have you connected the suction and discharge side correctly?
- Does the direction of rotation of the drive match the direction of rotation of the pump?
- Are the gate valves, flaps and valves in the system in the correct position?
- Has the piping system been checked for leak points?
- Can the pump be shut down in an emergency if a malfunction occurs during the first start that was not detected or was not foreseeable?
- Is there enough and the right pumped medium in the storage tank?
- Temper the pump before commissioning if the temperature difference between the pump and the pumped medium is greater than 50 °C!
- Is the pump grounded?



Assembly work may only be carried out when the drive unit is switched off.

6.3 Commissioning

Carry out any necessary disinfection of the pump head and the piping system.

- In order not to contaminate the medium to be pumped, a rinsing process lasting at least five minutes with the desired pumped medium and the appropriate speed is recommended to remove all residues of the test medium from the pump head.

NOTE Fitter must always wear personal protective equipment (goggles, shoes). During commissioning, attention must be paid to leaks. If medium leaks, the inflow to the pump must be stopped immediately and the leak must be repaired.

6.4 Monitoring

The operator is solely responsible for carrying out monitoring measures.

Consider the ATEX Directive, manufacturers and operators of non-electrical equipment undertake to prove safety in potentially explosive atmospheres. Even with a combination of individual devices, safety in potentially explosive areas must be ensured. It must be checked that no new ignition sources are created, and appropriate measures may have to be initiated.

When checking for leakage in the magnetic coupling area, make sure that the following points are met:

- Immobilizing the drive unit
- Cooling of the pump unit to room temperature
- Carrying out the inspection only outside of an Ex-atmosphere.

To detect a leak in the magnetic coupling area at an early stage, you must

- after commissioning,
- at regular intervals



unscrew the plug screw (26) and check whether leakage fluid has collected in the flange (7). Make sure that in the event of a leak, the pump is not put back into operation until the leak has been eliminated.

Risk of injury:

In the event of a leak, hot, toxic or corrosive liquid may leak. Wear appropriate protective equipment.



Replace the plug screw after verification. A pump without a plug screw must not be used in hazardous areas!

6.5 *Decommissioning*

Additional information when using the pump in a potentially explosive environment



- Before starting work, ensure that there is no explosive atmosphere outside the pump.
- Empty the pump head completely by reducing the back pressure to 0 bar and not sucking in any other medium.
- The pump may only be emptied under the supervision of a suitably qualified person.



- If hazardous media has been pumped, rinse the pump head with a suitable cleaning or neutralizing solution for several minutes.
- Finally, the pump head must be rinsed again with water.
- Close the gate valves (if equipped) before and after the pump. Close the shut-off devices only when the pump is stationary for a longer period of time (in the case of automatic systems, only when the entire system is taken out of service).

7 Maintenance / Cleaning

7.1 Additional information when using the pump in a potentially explosive environment



- Maintenance work on the pump must only be carried out in an environment without an explosion atmosphere.
- The proper functioning must be ensured by regular checks (for leakage, noise, temperature, odour, ...).
- If leakage fluid leaks, the leak site must be investigated immediately and the cause eliminated.
- After checking for leakage in the coupling area, the plug screw must be reinserted. Operation without a plug screw is not permitted in potentially explosive atmospheres.
- When replacing parts, use only original spare parts.
- After carrying out repair or replacement work, the proper functioning of the pump and all safety devices must be ensured.
- When cleaning painted pump surfaces, use appropriate antistatic aids.

Further information on the individual components can be found in the respective supplier documentation. The information provided by the individual manufacturers must be observed.

7.2 Safety instructions for maintenance, inspection and assembly work

As the operator, you are responsible for ensuring that all maintenance and installation work is carried out by authorised and qualified specialist personnel who have been sufficiently informed by studying the operating instructions in detail.



As a matter of principle, work on the pump must only be carried out at a standstill.

- Before all assembly and maintenance work, the motor must be de-energized or locked.
- Pumps or units that convey hazardous media must be decontaminated.
- Personal protective equipment must be worn ([personal protective equipment](#))
- Immediately after completion of the work, all safety and protective equipment must be reinstalled and put into operation.
- Before commissioning, the points listed in ([Commissioning / Decommissioning](#)) must be observed.

7.3 Maintenance cycle

The pump is not subject to fixed maintenance cycles.

Cleaning / maintenance is necessary if:

- the pump is stored,
- the pump is taken out of service for a longer period of time,
- The pump no longer meets the key data shown in the Technical Data chapter ,
- another medium is promoted,
- Leaks occur at the pump.

Please also note the information on transport ([transport and interim storage](#)) and the information on troubleshooting ([malfunction](#)).

It should be noted that during all maintenance work during which the pump is disassembled, all O-rings must be replaced during reassembly. Otherwise, absolute leakage safety is not guaranteed.

It is also important to keep the workplace absolutely clean, as dirt can jeopardize the proper functioning of the pump.

8 Fault, causes and elimination

Number	Type of fault
1	The pump does not prime.
2	The pump builds up no or too little pressure.
3	The pump produces noise.
4	The pump heats up.
5	The pump works loudly and/or vibrates/oscillates very strongly.
6	The pump is blocked.

Disruption						Cause and elimination of the disorder
1	2	3	4	5	6	
x			x			<p>The pump runs dry</p> <p>There is no medium on the suction line, or the suction height is greater than 3 m.</p> <p>Operation of pumps with PEEK gears without medium lasting longer than 30 s can destroy the pump and should therefore be avoided.</p> <p>Operation of pumps with Nitronic 60, Waukesha 88 or steel gears without medium is not permitted.</p> <p>The pumps of this series with PEEK gears are dry up to 3m self-priming. However, the suction behavior can be increased even further if the pump is filled with medium before commissioning.</p>
x						<p>Piping incorrectly designed</p> <p>Incorrectly sized piping can affect the suction behavior of the pump</p> <p>Extremely negative influence. Please note the information in (connecting cables)</p>
x						<p>Pressure / suction line closed</p> <p>If a shut-off valve is integrated on the pressure/suction side, make sure it is open. If there is still air in the pressure line, make sure it can escape.</p>
x	x			x		<p>Pump components worn</p> <p>If the pump no longer primes under the same operating conditions and the suction and discharge line is not closed, the pump will probably need to be repaired.</p>
x						<p>Suction line is leaking</p> <p>Make sure that the suction line is gas-tight so that no ambient atmosphere can be sucked in.</p>
x						<p>Connecting cable is not correct</p> <p>Check whether suction and discharge lines are reversed.</p>
x	x				x	<p>Foreign bodies, dirt and/or deposits may block the pump.</p> <p>As a rule, these can only be analysed / rectified by dismantling the pump (pump body)</p>
x						<p>Check the motor connection</p> <p>The engine may be incorrectly polarized. See the engine manufacturer's owner's manual.</p>
x						<p>Incorrect direction of rotation of the pump</p> <p>See direction of rotation on the type plate of the pump.</p>

Disruption	Cause and elimination of the disorder
------------	---------------------------------------

1	2	3	4	5	6	
x	x					Pipeline closed If there are shut-off valves in the pipeline on the pressure or suction side, make sure they are open.
x	x	x				Magnetic coupling uncoupled The disengagement of the magnetic clutch is accompanied by a rattling sound. The magnetic coupling serves, among other things, as overload protection (mounting of the magnetic coupling). In order to achieve a decoupling of the magnetic coupling, there must be an operating condition that is (at least temporarily) above the pump specification. Stop the drive and start the pump again. If the error recurs, fix the causes. Possible causes can be: <ul style="list-style-type: none"> - Differential pressure too high - Media viscosity too high - Dirt in the pump
	x					Media viscosity too low The hydraulic efficiency of the pump depends on the viscosity (viscosity of the medium). If the viscosity drops too far (due to the medium or too high temperatures), this can lead to a drop in the flow rate. Compare the current viscosity and temperature with the delivery viscosity and temperature and correct them if necessary (limit values).
		x				Cavitation plant Due to an impermissibly low inlet pressure (abs.) or an impermissibly high suction head, vapour bubbles form in the suction area of the pump depending on the vapour pressure of the medium. These implode on the pressure side and lead to increased wear and tear on the pump. This point of operation is to be avoided by changing the inlet conditions. Audible through the singing noise. Increase inlet pressure by reducing line resistance. Lower the temperature of the medium.
			x			Heating during operation Please first check whether it is not normal heating by the medium to be pumped. The pump surface takes on the temperature of the medium after a short time.
			x		x	Temperature range of the medium or permissible pump temperature exceeded Check if the temperature range of the medium has been exceeded (temperature classes and permissible temperature)
		x				Component wear If grinding noises are heard, this is an indication of wear in the pump. The pump must not continue to be operated in this way under any circumstances. Stop the drive immediately. Repair or replacement of the pump is mandatory.
				x		Unfavourable mounting conditions Significant oscillations and vibrations do not occur in normal operation. In individual cases, depending on installation conditions, oscillations and vibrations can be limited by the following measures: <ul style="list-style-type: none"> - Underlay the engine with vibration-damping pads. - Fasten the connecting cables with vibration-damping elements.

9 Components

9.1 Bill of Materials

Pumps:

5G13...

5G21...

5G35...

Pos.	Quantity	Description
1	1	Case
2	1	Lid
3	1	Drive shaft
4	1	Running shaft
5	1	Drive Gear
6	1	Running Gear
7	1	Intermediate flange $\varnothing 160$
8	1	Magnetic clutch hub
9	1	Magnetic clutch bell
10	1	Motor clutch hub BG 80
10	1	Motor clutch hub BG 90
10	1	Motor clutch hub BG 100
10	1	Motor clutch hub BG 112
11	1	Containment Shell
12	1	Centering ring
20	9	PEEK Plain Bearings
20	5	SSiC Plain Bearings
21	4	Cylindrical pin
22	6	Socket screw
23	8	Socket screw
24	4	Socket screw
25	4	Socket screw
26	1	Drain plug
28	1	Threaded pin engine size 80
28	1	Threaded pin engine size 90, 100, 112
29	2	O-Ring
30	1	O-Ring
31	2	Sprengtring
32	1	Feather
33	4	Retaining ring
40	1	Engine
41	4	Socket screw
42	1	Mounting Foot
43	4	Socket screw

The exploded drawing can be found in the [\(pump body\)](#)

10 Technical data

Note: Special pump designs may differ from the dimensions below.

10.1 Connection dimensions on the engine side

Engine size	a	b	c	d	e
80	19	6	21,5	36,3	132,9
90	24	8	27,3	46,3	132,9
100	28	8	31,3	56,3	132,9
112	28	8	31,3	56,3	132,9

Connection dimensions suitable for motors according to IEC 60072

10.1.1 PK version

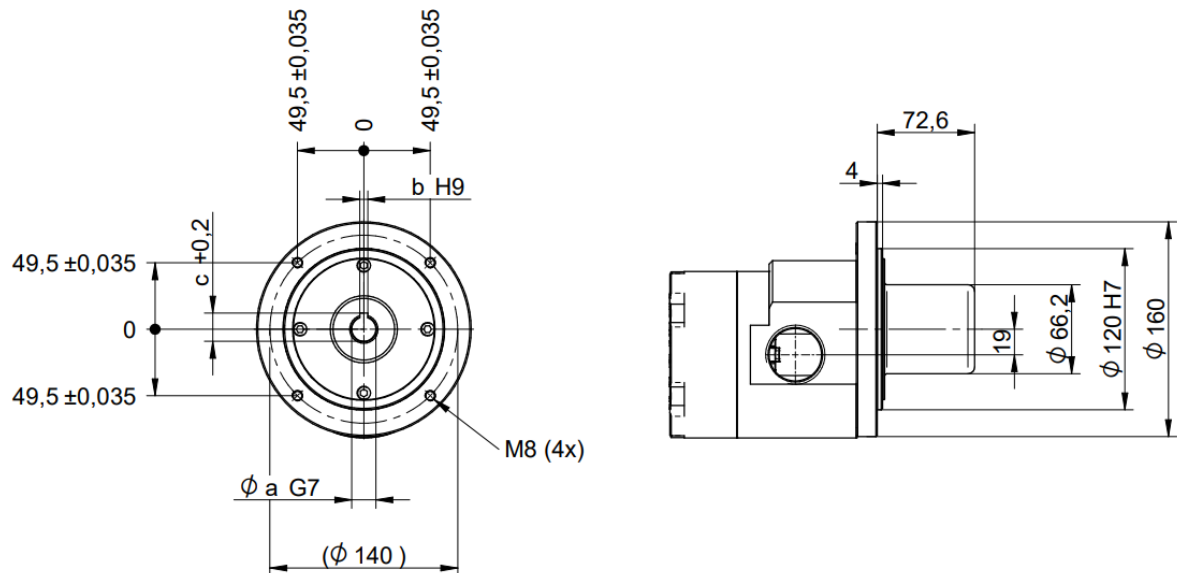

10.1.2 MK version

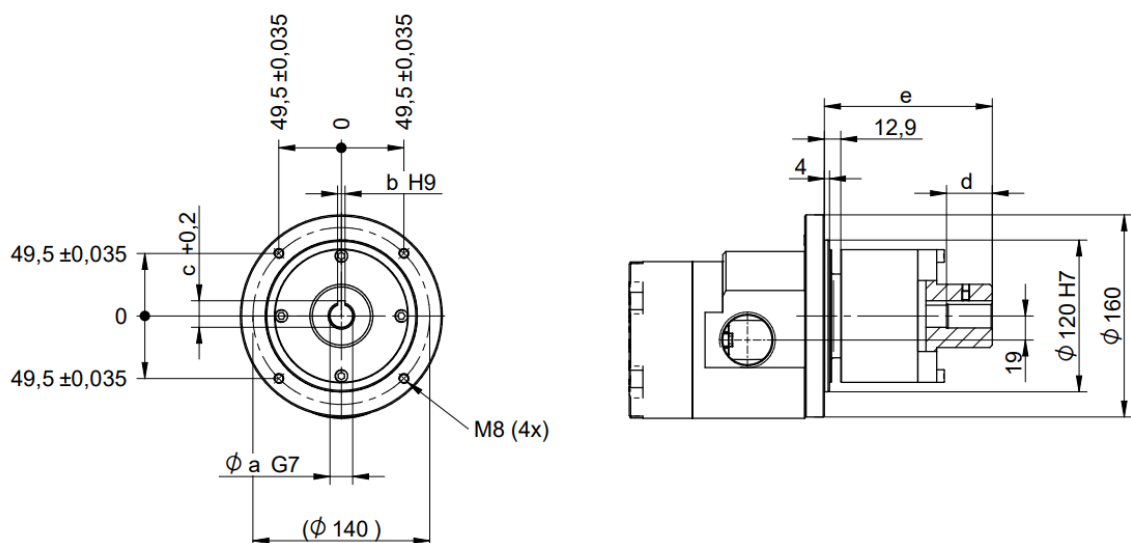

10.1.3 ZK version

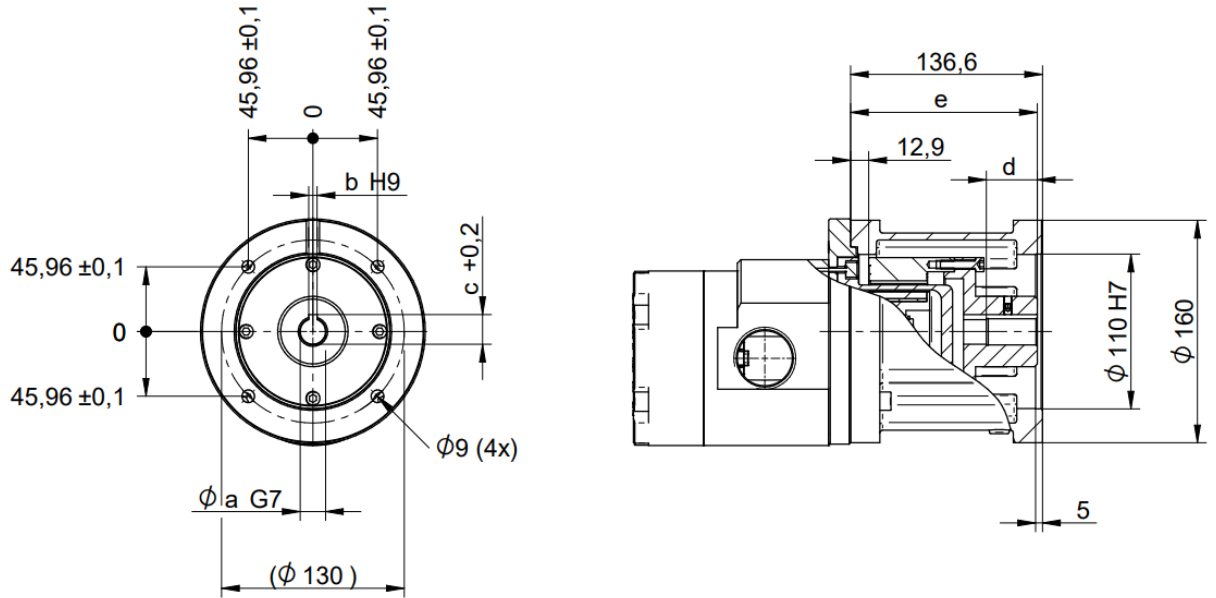

For engine size 80

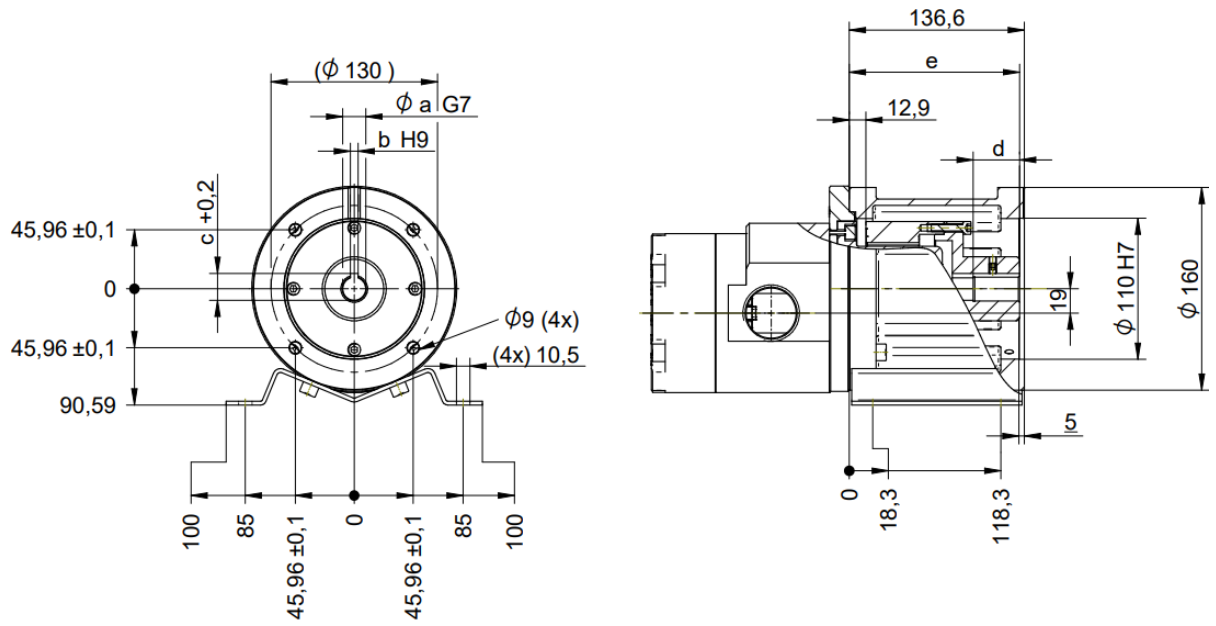

10.2 Connection dimensions on the pump side and motor connection

Pump version *	Engine size															
		a	b	c	d	E/ A		f	g	m/r	i	k	l	m/r	n	p
					G	NPT										
5G13	80	18,3	118,3	154,5	1"/65,5	1 1/4" /65,5	170	10,5	20/65,5	11,1	23,8	75	20/65,5	14	14	
5G13	90S	192,5	292,5	154,5	1"/65,5	1 1/4" /65,5	140	9	20/65,5	11,1	23,8	75	20/65,5	14	14	
5G13	90L	192,5	317,5	154,5	1"/65,5	1 1/4" /65,5	140	9	20/65,5	11,1	23,8	75	20/65,5	14	14	
5G13	100	199,5	339,5	154,5	1"/65,5	1 1/4" /65,5	160	12	20/65,5	11,1	23,8	75	20/65,5	14	14	
5G21	80	18,3	118,5	154,5	1"/53,5	1 1/4" /61	170	10,5	25/53,5	15,1	29,35	100	25/53,5	18	24	
5G21	90S	192,5	292,5	154,5	1"/53,5	1 1/4" /61	140	9	25/53,5	15,1	29,35	100	25/53,5	18	24	
5G21	90L	192,5	317,5	154,5	1"/53,5	1 1/4" /61	140	9	25/53,5	15,1	29,35	100	25/53,5	18	24	
5G21	100	199,5	339,5	154,5	1"/53,5	1 1/4" /61	160	12	25/53,5	15,1	29,35	100	25/53,5	18	24	
5G35	90S	192,5	292,5	170,5	1 1/2" /58,8	1 1/2" /61,5	140	9	32/76,8	15,1	29,35	110	32/76,8	18	24	
5G35	90L	192,5	317,5	170,5	1 1/2" /58,8	1 1/2" /61,5	140	9	32/76,8	15,1	29,35	110	32/76,8	18	24	
5G35	100	199,5	339,5	170,5	1 1/2" /58,8	1 1/2" /61,5	160	12	32/76,8	15,1	29,35	110	32/76,8	18	24	

10.2.1 Motor version with connection according to DIN ISO 228 or ANSI B1.20.1

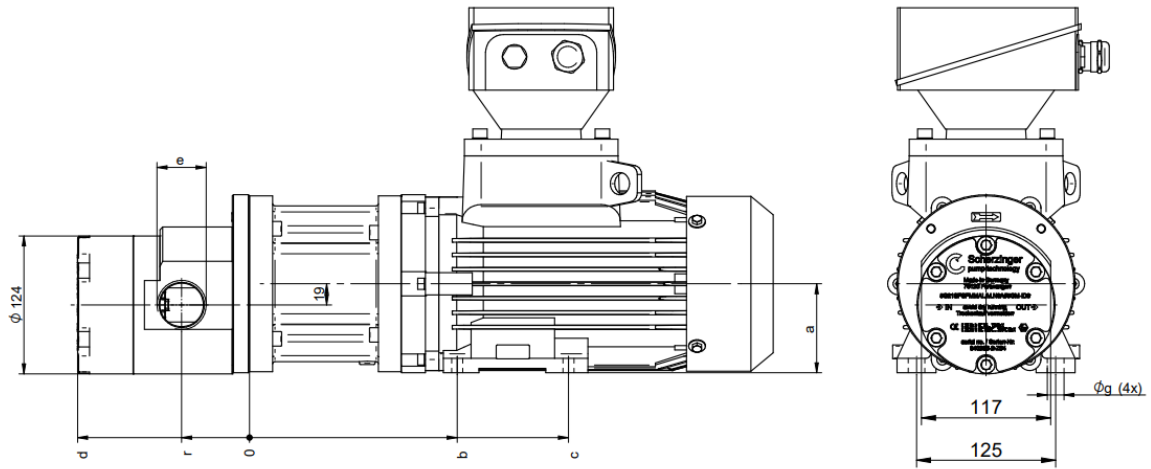

For engine size 80

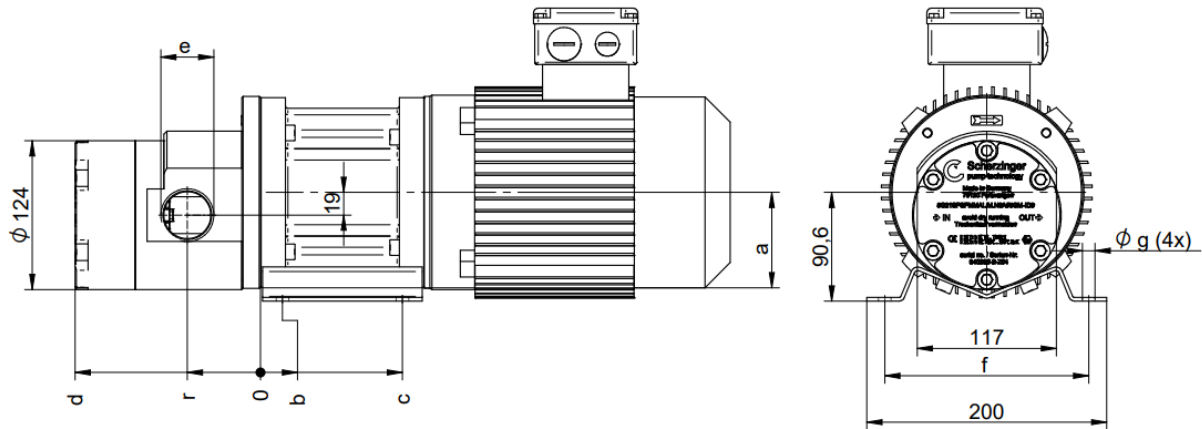

10.2.2 Motor version with connection for SAE-ISO 6162-1

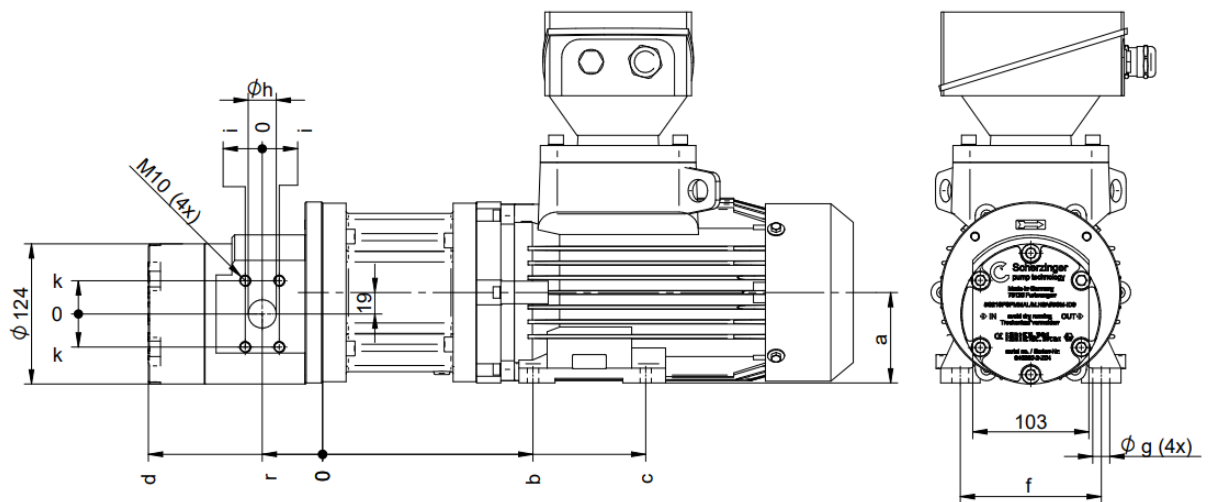

10.2.3 Motor version with flange EN 1092-1

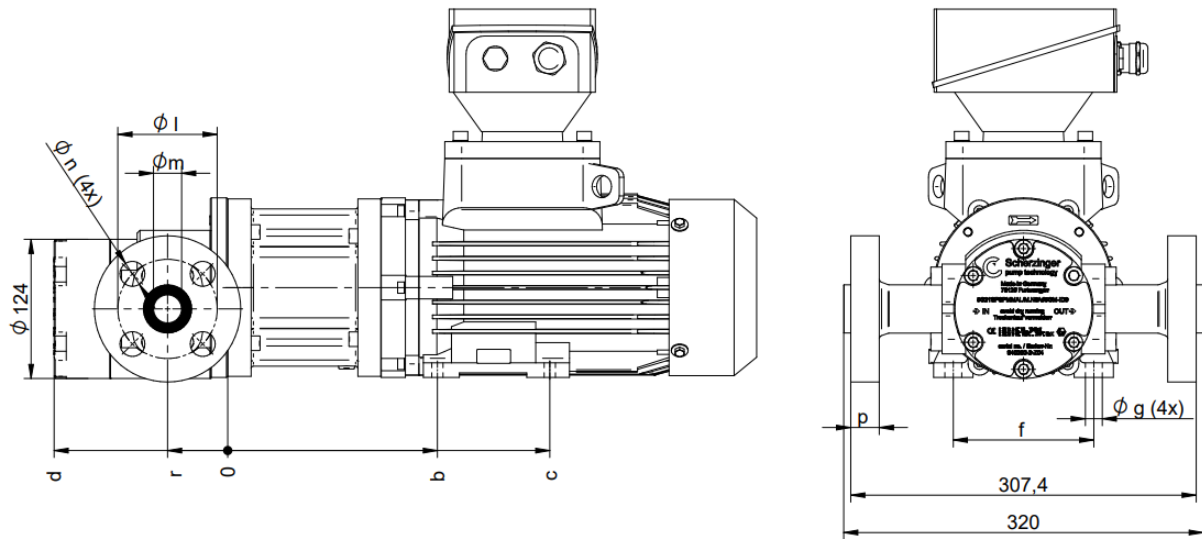

10.3 Sound pressure level

The measurement of the sound pressure level was carried out under the following conditions:

Distance between the transducer and the pump: 1 m

The sound pressure level of the pump is below 80 dB(A) for all operating points.

Note on sound pressure level:

- The pump is measured with a decoupled structure, on rubber feet and with hose elements to dampen the suction and discharge line.
- In the event of cavitation of the pump (e.g. too small suction line) and/or structure-borne noise due to vibrations of the entire system (pump/system), the above value can be exceeded by up to 10 dB(A).

10.4 Non-ionizing radiation

The pump with magnetic coupling emits non-ionizing radiation in the form of a magnetic field. This can destroy magnetically sensitive products.



These products include, but are not limited to:

- implanted medical devices (e.g. pacemakers),
- Credit cards,
- electrical, electronic, precision mechanical devices (e.g. hard drives).

Disposal

The pump can be disassembled into its components after correct decommissioning ([decommissioning](#)) and after removing the medium and removing any grease residues that may be present, and these can be recycled according to the materials used.

You must dispose of the pump, pump accessories and pumped media in accordance with valid nationally applicable regulations.



Pump components can be contaminated by toxic or radioactive pumped media. Before disposing of these components, you must clean them with the appropriate detergents. Adapt the detergent to the last medium pumped to rule out a dangerous chemical reaction between the pumped medium and the detergent. Wear the appropriate protective equipment.

The pump manufacturer assumes no responsibility for disposal.

10.5 Disposal of the pumped medium

The pumped medium must be disposed of in an environmentally friendly manner and in accordance with regional and national regulations.

- Make sure that the pumped medium does not get into the environment.
- Dispose of the pumped medium in suitable containers that comply with the regulations.

11 Appendix

11.1 Revision List

Revisions-Nr.	Description	Date	Author	Approved

11.2 Signature list

Procedure / Filling out the signature list

- Copy the list of signatures below.
- Enter the address of your company / authority and confirm it with the company stamp.
- Arrange for each employee who works with the product to sign this signature list to confirm that he/she has read and understood the operating instructions. Persons who do not confirm this with their signature are not authorized to work with the product!
- Then archive this list with your files.

Signature list

of the company / operator:

Address / Stamp

The persons listed below confirm by their signature that they have entered

- the function,
- the operation,
- maintenance, cleaning
- the installation

of the product (pump) and that they have read and understood the safety instructions in the operating instructions.

Participant surname, first name	Date of signature	Instructing surname, first name, date, signature



Address:

Scherzinger Pumpen GmbH & Co. KG
Bregstraße 23 - 25
78120 Furtwangen / Deutschland

Postal address:

Scherzinger Pumpen GmbH & Co. KG
P.O. Box 11 54
78120 Furtwangen / Deutschland

Communication:

Phone: +49 7723 6506-0

E-mail: info@scherzinger.de

Internet: www.scherzinger.de