

Performance Spectrum

Heart of Hightech



**Gear Pumps for
Mechanical Engineering**

Gear Pumps as universal lubrication and feed pumps

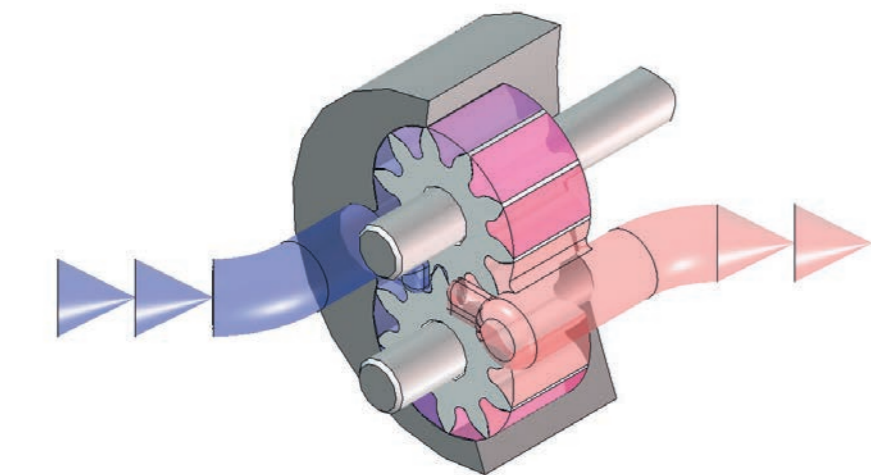

Functional principle

Gear pumps belong to the group of rotating displacement pumps. They pump fluids by means of two intermeshing rotors. A distinction is made between external and internal gear pumps, depending on the gear teeth design. The rotor fitted on the driven shaft of the gear pump transfers the rotary movement to the second rotor. A fluid volume proportional to the speed is displaced by the rotation. This allows fluids even to be extracted and pumped against high pressures.

As a specialist for rotating displacement pumps, Scherzinger's focus with regard to the described pumps is solely on all-purpose external gear pumps. Due to the low inner friction values, this pump principle is very energy-efficient and the pump is subject to a low degree of wear.

Structural design

One gear is driven by means of the drive shaft. The other gear is turned by the tooth engagement. The fluid is extracted through a tooth space opening in the tooth engagement area.

The fluid flows through the inlet duct on the suction side into the gear pre-chamber and then into the tooth spaces.

The effect of the rotation is that the fluid is transported along the pump casing wall in the gear spaces to the outlet and then squeezed out.

Shafts with gears fitted on them are installed with sleeve bushings on both sides of the pump casing and cover in order to absorb high bearing loads.

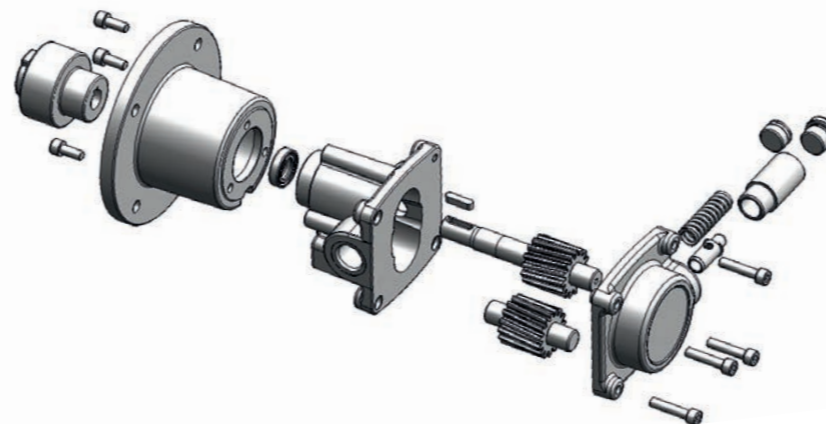

Applications and areas of application

Scherzinger gear pumps are used for lubricating media, ranging from diesel to heavy oil.

The pump can be used:

- for low-viscous to medium-viscous, particle-free fluids
- for fluids with good lubricating properties
- for differential pressures 0 to 30 bar
- at inlet pressures of -0.8 mbar (absolute) to 10 bar overpressure
- for speeds of 0 – 1.800 rpm
- in normal as well as explosive atmospheres (ATEX II 2G)

Examples of application are:

- **Paint and varnish:** Transfer of paint and varnish during the production process
- **Cooling and air compressors:** Lubrication of connecting rod bearing and crankshaft bearings
- **Transmission:** Lubrication of roller bearings and tooth flanks for increased torques
- **Generation of industrial process heat:** Filling and draining of thermal oil systems
- **Wind power stations:** Lubrication of large transmissions
- **Steam turbines:** Lubrication of reduction gears

Frequently pumped media

- Lubricating oil
- Thermal oil
- Hydraulic oil
- Paint and varnish
- Emulsions
- Cocoa paste
- Liquid soap
- Heat transfer fluid
- Vegetable oil
- Diesel
- Polyol
- Glycol
- Wax

Gear pumps as universal lubrication and feed pumps



Implementable flow rates

Pumpe	vg (ml/rev)	Pump speed (rpm)						
		470	690	830	950	1150	1450	1750
51	2.1	0.97	1.43	1.72	1.97	2.38	3.00	3.62
76	2.8	1.32	1.93	2.32	2.66	3.22	4.06	4.90
101	4.0	1.90	2.79	3.35	3.84	4.65	5.86	7.07
151	5.7	2.68	3.94	4.74	5.42	6.57	8.28	9.99
251	10.9	5.12	7.52	9.05	10.4	12.5	15.8	19.1
351	20.9	9.83	14.4	17.4	19.9	24.1	30.3	36.6
451	31.0	14.6	21.4	25.7	29.5	35.7	45.0	54.3
551	49.0	23.0	33.8	40.7	46.6	56.4	71.1	85.8

The flow rate of gear pumps is virtually proportional to their speed.

The adjacent table shows the possible flow rates of the respective pump sizes in l/min.

The dimensions are based on media viscosity of 50 mPas and non-pressurized pumping.

The selected pump speeds correspond to the available rated speeds of standardized industrial motors operated at 50 and 60 Hz.

If the differential pressure is increased or the viscosity reduced, the actual flow rate drops due to the gap losses.

Please also observe that the maximum possible differential pressure is lower at lower viscosity. At high viscosity, the pump speed must be reduced to avoid cavitation.

Application limits

	Basic range	Customer-specific applications
Temperature range	-20 ° to 160 °C	-40 ° to 250 °C
Differential pressure	30 bar	40 bar
Inlet pressure	-0.8 to 10 bar	-0.9 to 10 bar
Viscosity range	2 to 30,000 mPas	1 to 50,000 mPas

Performance curves of pump sizes 51 and 76

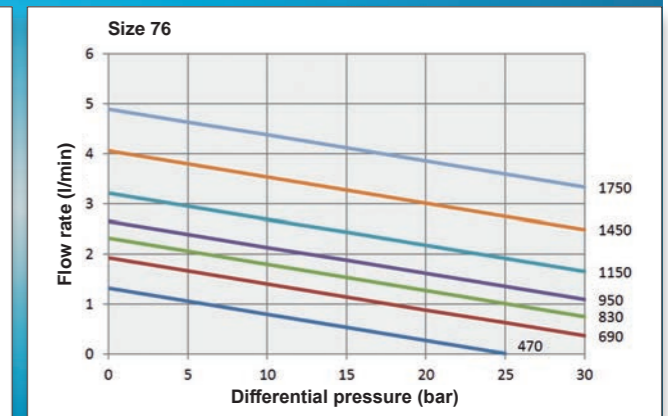
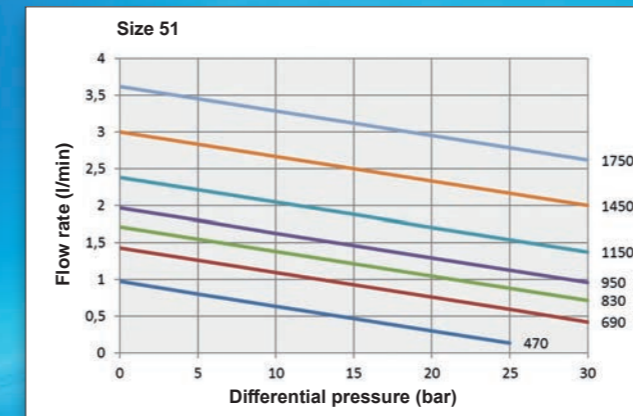

Performance curves of pump sizes 101 and 151

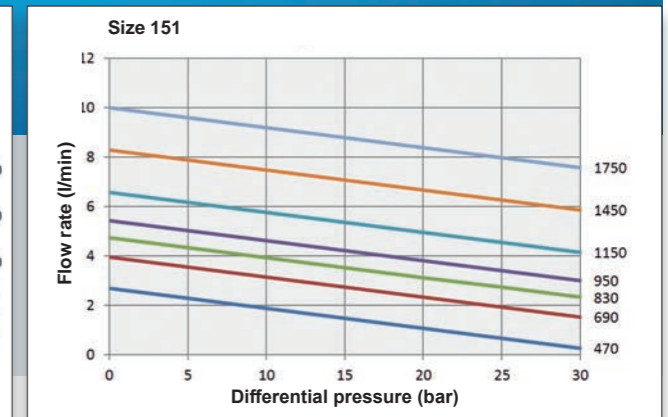
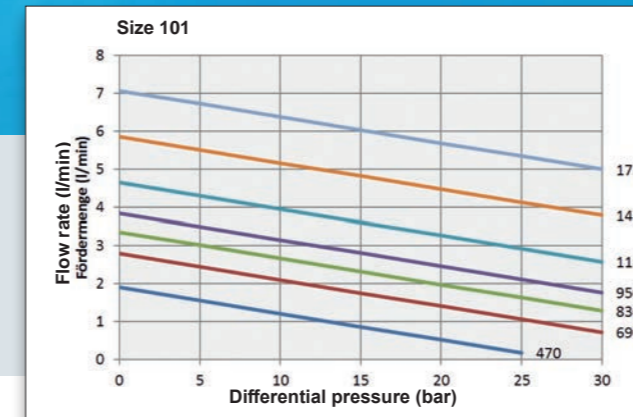

Performance curves of pump sizes 251 and 351

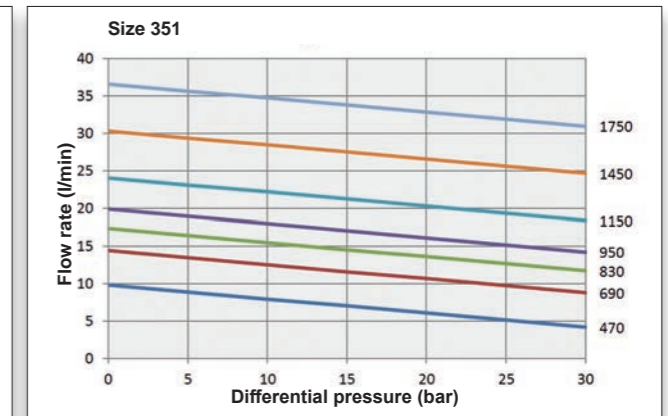
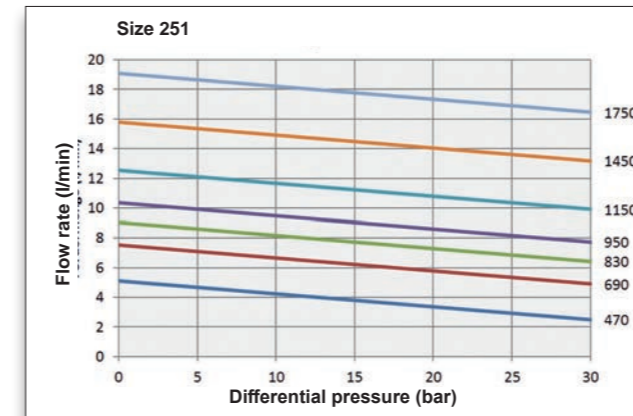

Performance curves of pump sizes 451 and 551

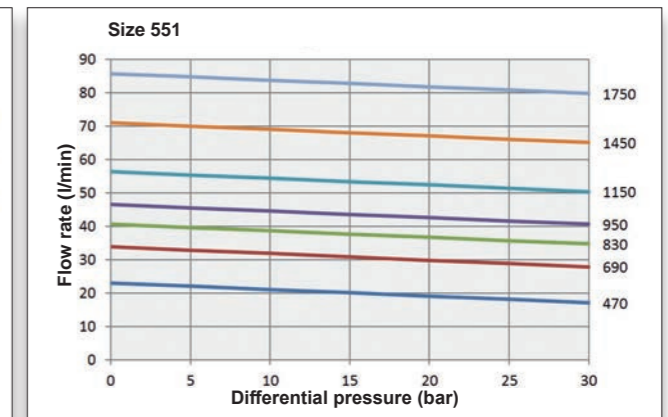
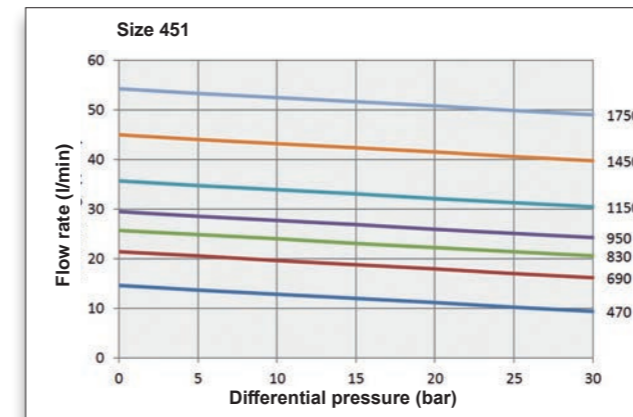

■ 1750 rpm | ■ 1450 rpm | ■ 1150 rpm | ■ 950 rpm | ■ 830 rpm | ■ 690 rpm | ■ 470 rpm

Lubrication and feed pumps

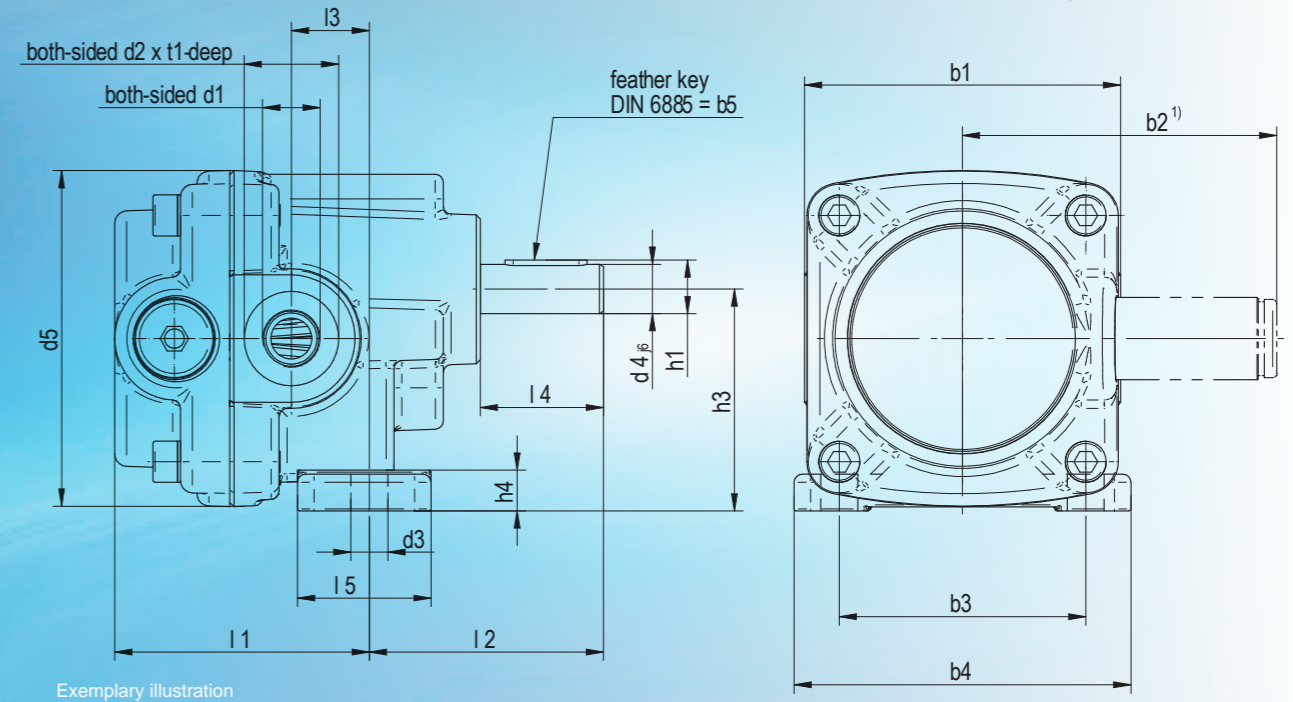

Exemplary illustration

Gear Pumps in foot-mounted design

An overview of your benefits

- Different sealing systems available
- Integrated, adjustable pressure relief valves to protect the piping
- Universal design on base frame
- Variable design of drives possible
- Low speeds for high viscosities possible
- Can also be used for particle-loaded media

Gear pumps of this design are mainly installed on a base frame for use. The very different drive concepts used by Scherzinger give you the freedom of choice in order to find the suitable drive for your application. For example, electric motors in foot-mounted design or gear motors are easy to adapt.

A version with reinforced radial bearing on the shaft end is available for driving by means of a toothed or V-belt. The drive and pump are ideally decoupled, thermally and mechanically.

Gear pumps of this design are available for different adjustment ranges with or without an adjustable pressure relief valve.

There are several shaft seal versions and materials available for selection. Single or double lip seal rings or packing versions are possible for application with viscous or abrasive media.

If necessary, the pumps can be supplied as customized designs also with shaft seals. The materials (NBR, FKM or EPDM) of all seals can be adapted to their application.

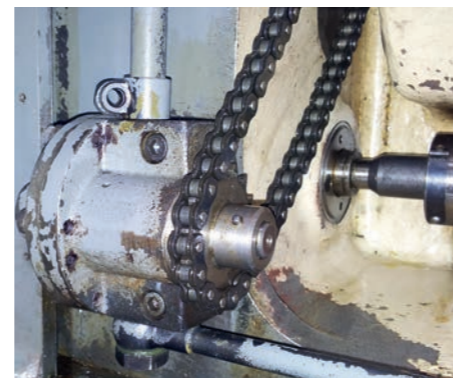
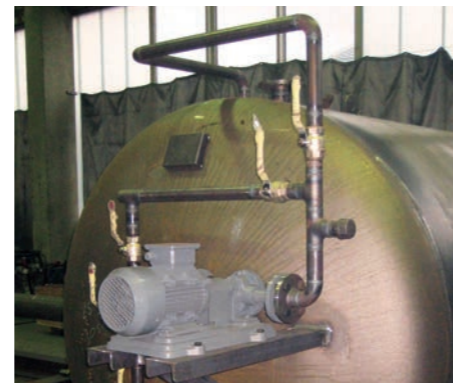

Dimensions of foot-mounted pumps (in mm)

Size	d1	d2	d3	d4	d5	b1	b2 ¹⁾	b3	b4	b5	Flow variations		Sealing variations	
											I1 ²⁾	I1 ¹⁾	I2 ³⁾	I2 ⁴⁾
											A	B	N	S
51	G 1/4	19	6.4	10	61	58	57.3	48	64	3	48	49	44	54
76	G 1/4	19	6.4	10	61	58	57.3	48	64	3	48	49	44	54
101	G 3/8	23	9	12	82	77	76.5	60	76	4	62	62	57	70
151	G 3/8	23	9	12	82	77	76.5	60	76	4	62	62	57	70
251	G 1/2	27	9	14	95	91	85.5	74	96	5	72	72	67	82
351	G 3/4	33	11.5	16	114	106.6	99	84	110	5	81	88	71	87
451	G 1	40	11.5	18	140	130.6	120	100	130	6	89	97	79	97
551	G 1 1/4	50	11.5	18	140	130.6	120	100	130	6	114	122	79	99

I3	Sealing variation		I5	h1	h2	h3	h4	t1	Weight ⁵⁾ kg	Flow rate ⁶⁾ rpm	P ⁷⁾ kW
	I4 ³⁾ N	I4 ⁴⁾ S									
15	25	24	24	11.3	30.9	40	7.5	0.8	0.9	2.7	0.09
15	25	24	24	11.3	30.9	40	7.5	0.8	0.9	3.4	0.11
19	30	32.1	32.5	13	42	54	10	0.8	2.15	5.2	0.17
19	30	32.1	32.5	13	42	54	10	0.8	2.2	7.4	0.26
22	32	33	44	15.2	50	65	11	0.8	3.4	14.9	0.56
25	34	35	49.27	17.2	58	77	10.27	0.3	4.86	28.4	0.96
26	37	39	60.13	20.5	71.3	94	11.77	0.3	8.5	43.2	1.5
26	37	41	60.13	19.6	71.3	94	11.77	0.3	10	69.1	2.3

Lubrication and feed pumps

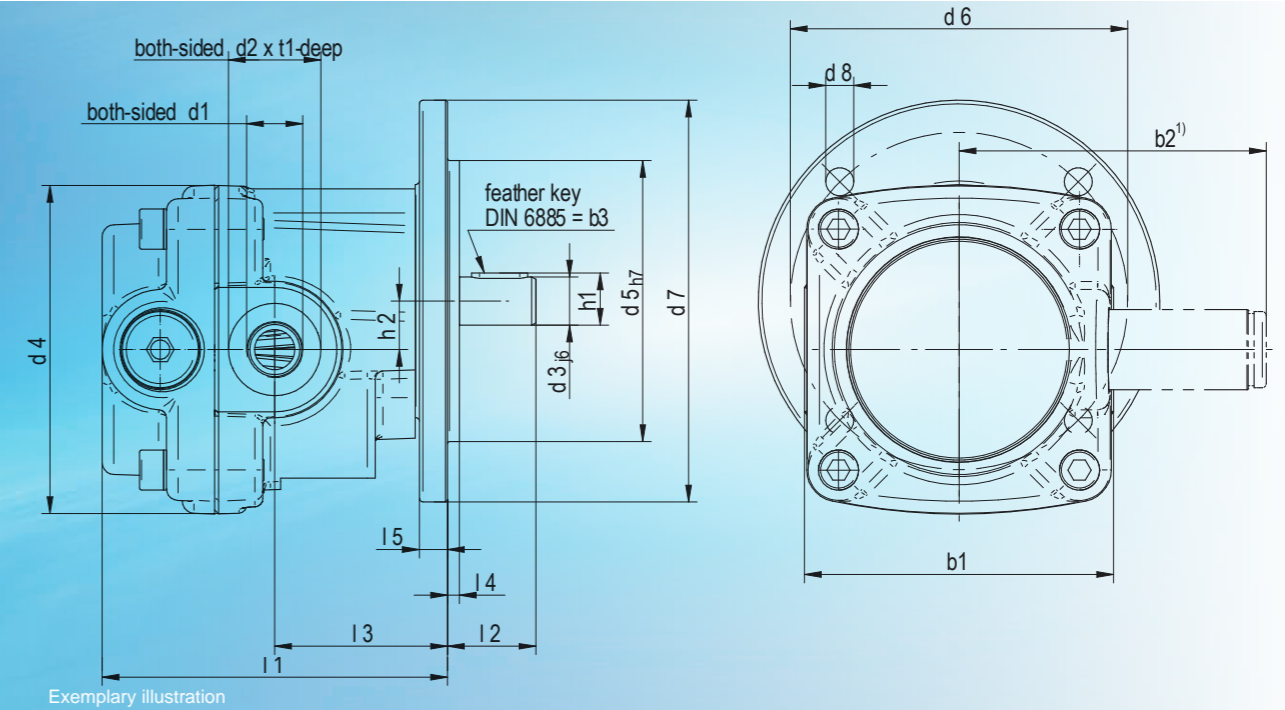

Gear Pumps in flange design

Dimensions of flange-mounted pumps (in mm)

An overview of your benefits

- Integrated, adjustable pressure relief valves to protect the piping
- Can be connected directly to your drive
- Variable connection of drives possible
- Low speeds possible

Gear pumps of this design are mainly used whenever the pump is to be connected to units with rotating shafts without a separate electric drive, usually in order to pump lubricating oil or fuel.

For example, the pump can be screwed directly onto a transmission casing.

The pump shaft is usually plugged into a hollow shaft in the process.

You do not need any additional coupling elements. Of course, connections with flexible couplings are also possible.

This allows the piping to be connected flexibly to the pump whenever necessary. Pumps of this design are available with or without an adjustable pressure relief valve, also for different adjustment ranges.

Single or double lip seal rings are available as shaft seals.

Of course, the seal materials can be varied to suit your application.

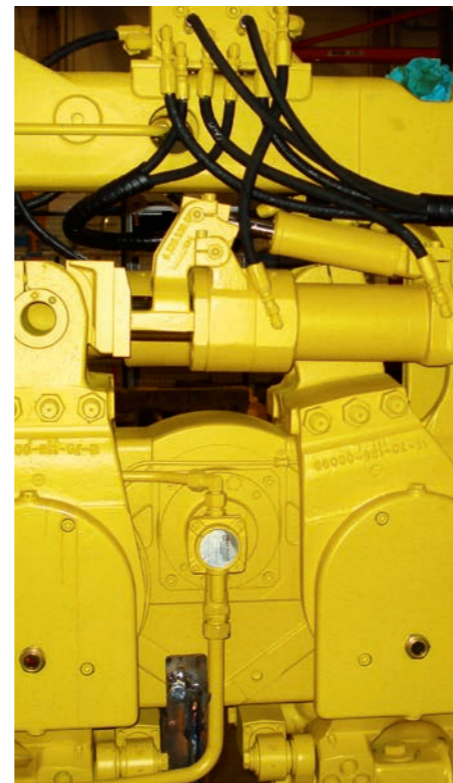

Size	d1	d2	d3	d4	d5	d6	d7	d8	b1	b2 ¹⁾	b3	Flow variations		l2	l3	l4	l5	h1	h2	t1	Wt. ³⁾	Fr. ⁴⁾	P ⁵⁾
												A	B										
												kg	rpm										
51	G 1/4	19	10	61	50	60	69.5	5.3	58	57.3	3	65	66	17	32	2	6	11.3	9.1	0.8	0.950	2.7	0.09
76	G 1/4	19	10	61	50	60	69.5	5.3	58	57.3	3	65	66	17	32	2	6	11.3	9.1	0.8	1.000	3.4	0.11
101	G 3/8	23	12	82	70	84	100	7	77	76.5	4	86	86	22	43	3	7	13	12.1	0.8	2.100	5.2	0.17
151	G 3/8	23	12	82	70	84	100	7	77	76.5	4	86	86	22	43	3	7	13	12.1	0.8	2.132	7.4	0.26
251	G 1/2	27	14	95	90	100	120	7	91	85.5	5	104	104	29	54	3	8	15.2	15.15	0.8	3.394	14.9	0.56
351	G 3/4	33	16	114	100	120	140	9.5	106.6	99	5	114	121	38	58	4	9	17.2	19	0.3	5.849	28.4	0.96
451	G 1	40	18	140	110	130	150	11.5	130.6	120	6	127	135	42	68	4	10	19.6	22.7	0.3	8.650	43.2	1.5
551	G 1 1/4	50	18	140	110	130	150	11.5	130.6	120	6	152	160	42	64	4	10	19.6	22.7	0.3	11.300	69.1	2.3

1) Dimension only applies to versions with pressure relief valve

2) Dimension only applies to versions without pressure relief valve

3) Maximum weight in kg

4) Flow rate at a speed of 1450 rpm with 50 mPas media viscosity and a differential pressure of 10 bar

5) Drive capacity required under the operating conditions of 4)

Lubrication and feed pumps

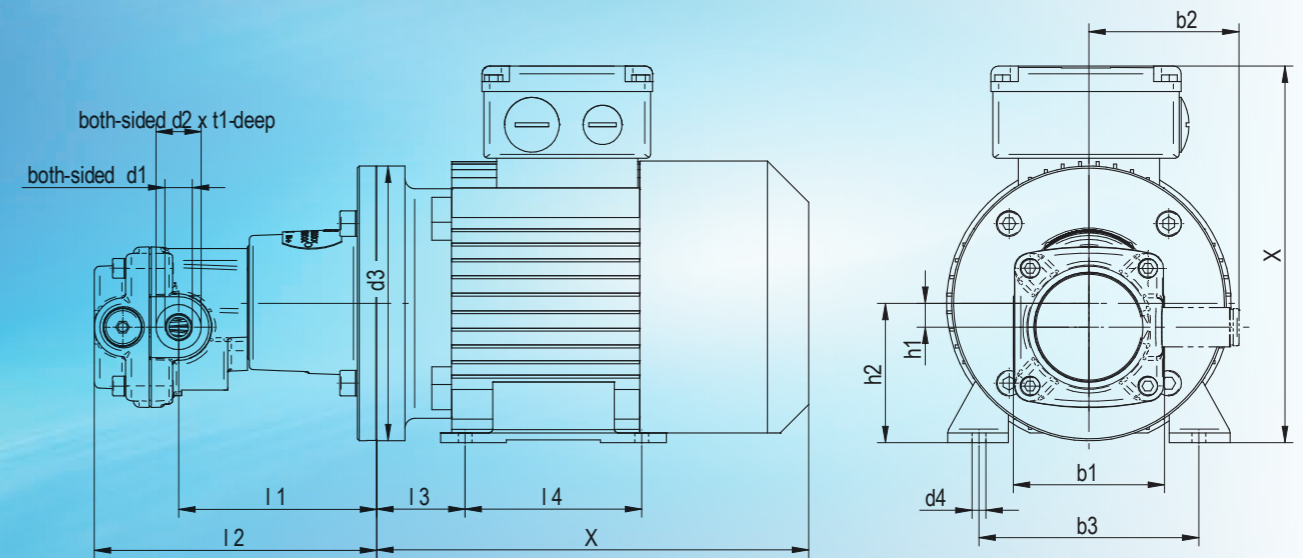

Exemplary illustration

X = manufacturer-specific

Gear pumps with electric motor

Dimensions of motor pumps (in mm)

An overview of your benefits

- Integrated, adjustable pressure relief valves to protect the piping
- Supplied with an electric drive
- Variable connection of drives possible
- Also available according to ATEX 94/9/EG

Gear pumps of this design can be used for a multitude of purposes for completely different applications.

The compact design allows universal installations due to the direct connection to an electric drive. The gear pump's shaft is firmly connected to the motor shaft via a flexible coupling.

The exact positioning of the pump on the electric motor is performed with a motor adapter.

These electric-motor-driven gear pumps are usually used for pumping processes, such as the transfer from storage tanks, as oil circulation pumps, as lubrication pumps or also as pumps for cooling lubricants. Electric drives are available in almost all commercially available versions. Various mechanical, electrical and also explosion-proof versions are possible.

Our gear pumps of this design are available with or without adjustable pressure relief valves, also for different adjustment ranges. Single or double lip seal rings are available as shaft seals. Of course, the seal materials can be varied application specifically.

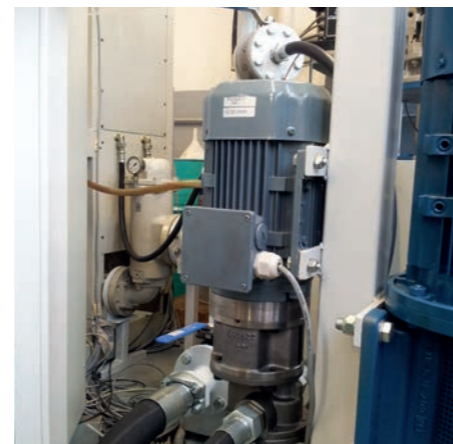

Size	d1	d2	d3	d4	b1	b2 ¹⁾	b3	l1	Flow variations		l3	l4	h1	h2	t1	suitable norm motor size IMB 14/34					
									I2 ¹⁾ A	B ²⁾						Motor size	Flange	P kW	Wt. ³⁾ kg	Fr. ⁴⁾ rpm	P ⁵⁾ bar
51	G 1/4	19	120	7	58	57.3	100	85	118	119	40	80	9.1	63	0.8	63	120	0.18	7.6	2.3	22
			112				90	123	124	45	90	71				71	140	0.37	9.1	2	30
76	G 1/4	19	120	7	58	57.3	100	85	118	119	40	80	9.1	63	0.8	63	120	0.18	6.8	3.2	16
			112				90	123	124	45	90	71				71	140	0.37	8.6	2.5	30
101	G 3/8	23	140	7	77	76.5	112	101	144	144	45	90	12.1	71	0.8	71	140	0.37	9.7	4.2	24
			125				111	154	154	50	100	80				80	160	0.75	21.6	3.8	30
151	G 3/8	23	140	7	77	76.5	112	101	144	144	45	90	12.1	71	0.8	71	140	0.37	9.7	6.9	17
			125				111	154	154	50	100	80				80	160	0.75	21.5	5.9	30
251	G 1/2	27	140	7	91	85.5	112	117	167	167	45	90	15.1	80	0.8	71	140	0.37	11.8	15.2	5
			125				137	187	187	50	100	80				80	160	0.75	22.8	14.5	14
			140				137	187	187	56	125	90				90L	160	1.5	19.4	13.1	30
			125				143	199	206	50	100	80				80		0.75	26.5	29	7
351	G 3/4	33	160	9	106.6	99	140	153	209	216	56	125	19	90	0.3	90L	160	1.5	25	27.1	17
			160				183	239	246	63	140	100				100L		3	35.2	24.7	30
			125				153	215	224	50	100	80				80		0.75	23.3	44.4	3
451	G 1	40	160	9	130.6	120	140	163	225	234	56	125	22.7	90	0.3	90L	160	1.5	26.7	43.2	10
			160				183	245	254	63	140	100				100L		3	39.7	40.6	24
			190				183	245	254	70	140	112				112M		4	54	39.7	30
551	G 1 1/4	50	160	12	130.6	120	140	183	270	279	56	125	22.7	100	0.3	90L	160	1.5	40	70	5
			160				183	270	279	63	140	100				100L		3	42.1	68.3	14
			190				183	270	279	70	140	112				112L		4	56.4	67.1	20

1) Dimension only applies to versions with pressure relief valve

2) Dimension only applies to versions without pressure relief valve

3) Maximum weight in kg

4) Flow rate at a speed of 1450 rpm with 50 mPas media viscosity and max. possible differential pressure according to 5)

5) Maximum possible differential pressure with the installed motor power

Additional equipment

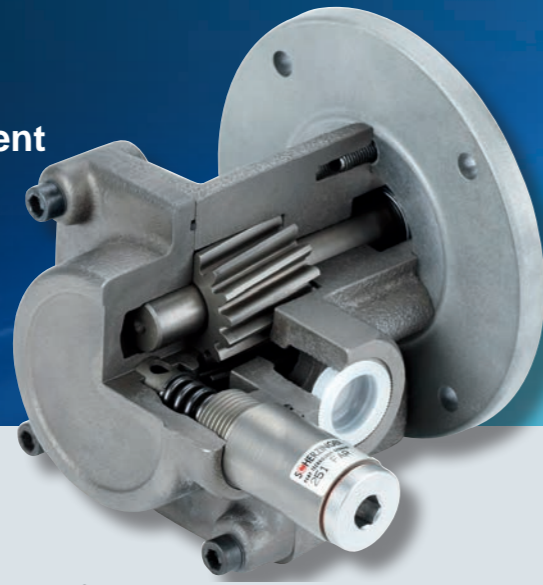

Direction of rotation

All gear pumps of this series are designed for one direction or variable direction of rotation.

They are available as counter-clockwise or clockwise versions and may always only be operated in the predefined direction of rotation. The direction of rotation is

Clockwise direction

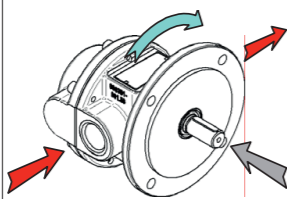

Clockwise direction of rotation suction side on the left pressure side on the right

defined with the view on the shaft end.

The direction of rotation is always determined with the view on the pump shaft end (gray arrow).

The direction of rotation is indicated by the blue arrow.

Counter-clockwise direction

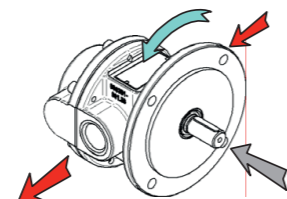

Counter-clockwise direction of rotation, suction side on the right pressure side on the left



Pressure relief valves

All gear pumps are available without or with an integrated pressure relief valve. The pressure relief valve is designed as a spring-preloaded piston valve.

The spring pretension and hence the set opening pressure can be varied within geometric limits by means of a setting screw. Different springs are available, depending on the desired adjustment range and the pump size.

Pressure control ranges in bar

	Feather 1	Feather 2	Feather 3
51 76	0 – 3	3 – 8	8 – 15
101 151	0 – 8	8 – 15	15 – 25
251	1 – 8	8 – 20	15 – 29
351	0 – 5	5 – 11	11 – 20
451 551	0 – 5	5 – 10	10 – 16

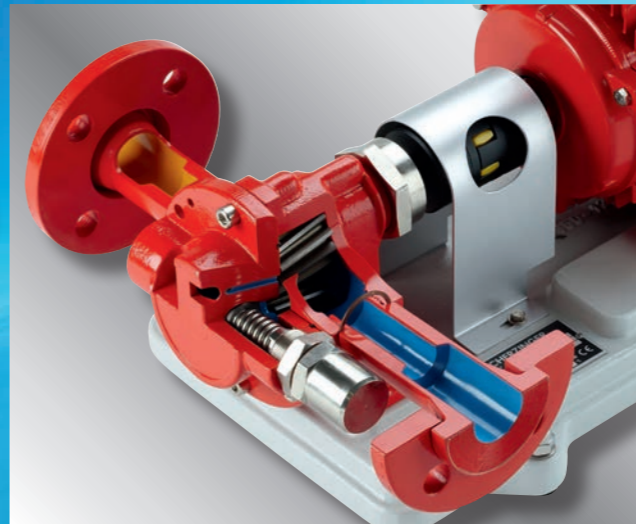

Line connections

Scherzinger gear pumps are distinguished by their great variability of materials as well as the number of different piping connection options.

For example, at least two different connection variants are possible for all versions.

All available connection options for installation in your system are specified in the following table.

Pump	BSP	NPT	ISO 1092-1 Form B, PN 16
51, 76	1/4 "	3/8 "	–
101, 151	3/8 "	1/2 "	–
251	1/2 "	3/4 "	DN 20
351	3/4 "	1 "	DN 25
451	1 "	1 1/4 "	DN 32
551	1 1/4 "	1 1/4 "	–

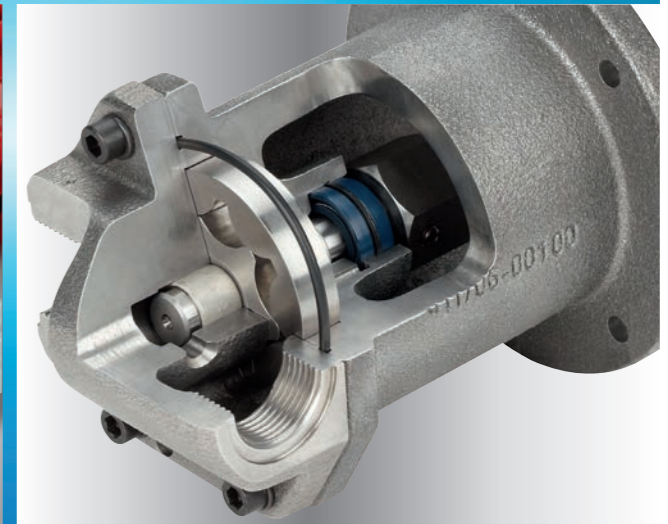

Shaft seals

Several types of shaft seals are available, depending on the pump version. The basic seal is a lip seal ring for pumping well-lubricating and low-viscous to medium-viscous fluids, such as lubricating oil.

It is recommended to use a packed gland for fluids with poor lubricating properties if the pumped fluid may harden or abrasive fluids are to be pumped.

To overcome high suction heads, we recommend using a double-acting lip seal ring for sealing, if possible filled with grease for permanent lubrication.

It can be slightly retightened in the event of wear and resulting leaks. Graphite and PTFE-soaked fabrics are mainly used as seal materials.

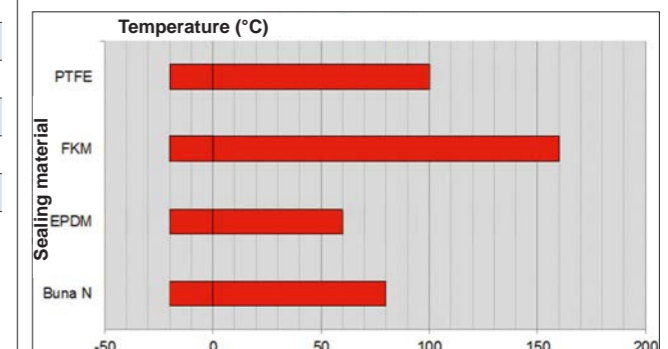

Application in potentially explosive areas and drive variants

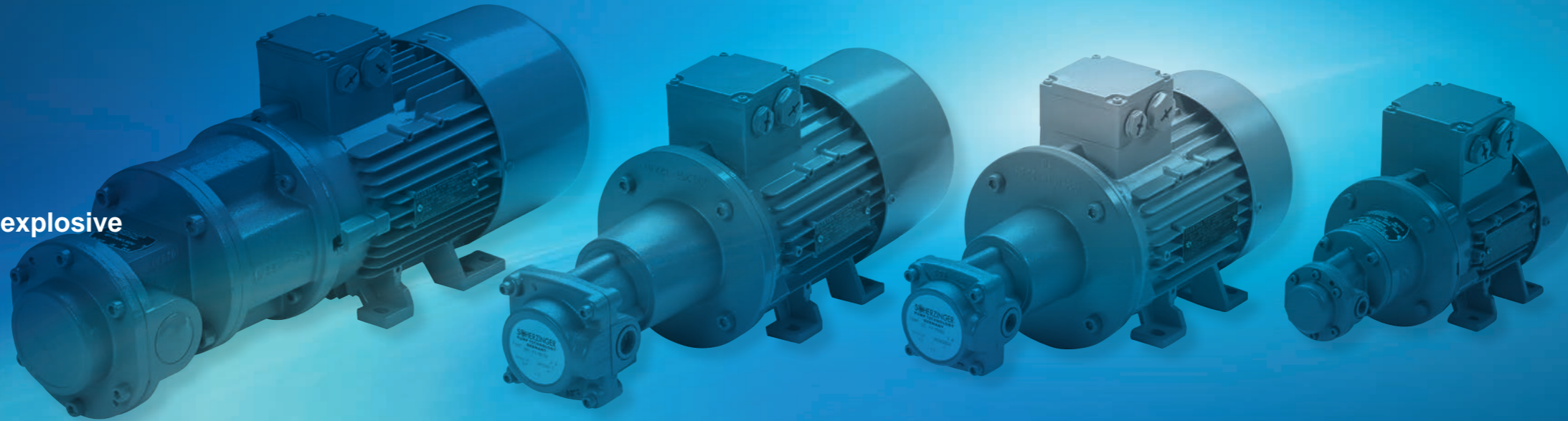

Application in potentially explosive areas

The gear pumps have been designed in such a manner that almost all versions comply with the standard ATEX 94/9/EC and can be used in potentially explosive areas.

Additional equipment may be necessary, depending on the pump size and the operating conditions. The adjacent overview shows the possible areas of application.

	II 2G Zone 1 Zone 2	II 2D Zone 21 Zone 22	With single- acting lip seal ring	With double- acting lip seal ring	With integrated pressure relief valve	With packing
51	■	■	■	■	—	—
76	■	■	■	■	—	—
101	■	■	■	■	—	—
151	■	■	■	■	—	—
251	■	■	■	■	—	—
351	■	■	■	■	—	—
451	■	■	■	■	—	—
551	■	■	■	■	—	—

Pump drives

Our gear pumps are prepared for connection to industrial squirrel-cage motors in compliance with the IEC standard.

The following table shows the combination options of the various pump and motor sizes.

The following drive variations are therefore possible with these motor sizes:

- Any connection voltages at 50 Hz or 60 Hz line frequency
- Fixed speed or pole-changing motors
- Increased safety or flameproof enclosure for potentially explosive areas

- Temperature sensors in the winding for temperature monitoring
- Different terminal box positions and cable outlets
- With external ventilation for low speeds at high torque
- Integrated or supplied frequency converters
- Drives in compliance with CSA or NEMA

Of course, it is also possible to connect drives adapted specifically to your application.

These are, for example:

- DC brush motors
- EC DC drives
- Gear motors, adjustable or with fixed speed
- Air motors

Pump	63	71	80	90	100	112
51	■	■				
76	■	■				
101		■	■			
151		■	■			
251		■	■	■	■	
351			■	■	■	
451				■	■	■
551				■	■	■

Gerotor Gear Pumps



Internal Gear Pumps



Structural design

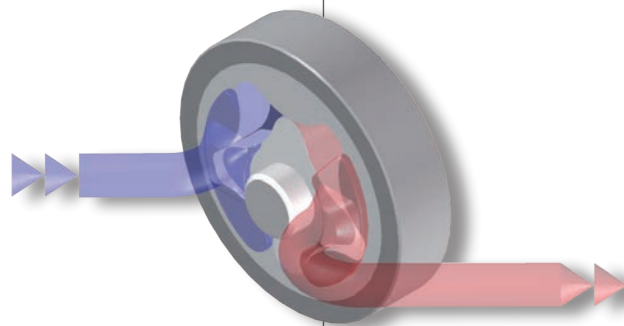

In addition to the external gear pump described above, Scherzinger also supplies internal gear pumps.

Gear pumps of this design are usually used as highly integrated units for oil lubrication in large-scale series. The cost benefit is achieved by using sintered displacers in combination with simple pump casing machining processes. Gerotor pumps are often designed as independent pumps without shafts of their own which are slipped

onto existing drive or intermediate shafts. No rotary shaft seals are usually required due to the high degree of integration in customer systems.

This type of gear pumps can also be designed very simply with rotational direction switchover for applications in which the direction of rotation of the drive shaft may change. The pumping direction is not changed even if the direction of rotation is changed.

Operational areas & possible applications

Application limits	
Customer-specific applications	
Δp :	max. 30 bar
Flow rate:	max. 200 rpm
Inlet pressure:	-0.7 to 100 bar
Suction head:	max. 7 m
Temperature range	-40 ° to 160 °C
Viscosity range:	-0.5 to 50,000 mPas

Possible applications:

Application cases are, for example, the lubrication of combustion engines, compressors, blowers, compactors or stationary or mobile transmissions.

These units usually have their own oil sump from which the pump conveys oil to the lubrication points via a filter.



Structural design

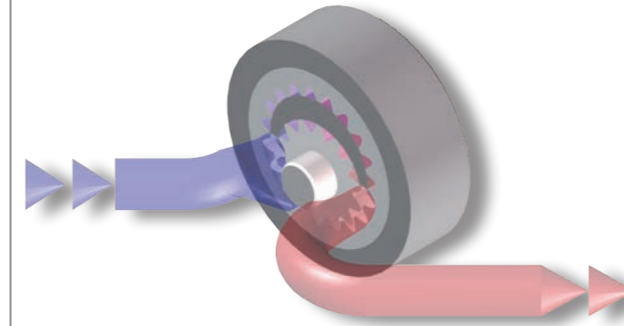

In addition to external gear pumps and gerotor pumps, Scherzinger also supplies internal gear pumps, also known as crescent pumps.

A particular advantage is the high degree of pumping uniformity with very low pulsation, resulting in very smooth running.

The long sealing sections within the pump enable the implementation of very high suction heads and high differential pressures of up to approx. 120 bar.

Since no compensation elements are required even at high pressures, the overall efficiency of this pump type is excellent.

Operational areas & possible applications

Application limits	
Customer-specific applications	
Δp :	max. 100 bar
Flow rate:	max. 1.5 rpm
Inlet pressure:	-0.7 to 100 bar
Suction head:	max. 9 m
Temperature range:	-40 ° to 200 °C
Viscosity range:	-0.5 to 2,000 mPas

Possible applications

Application cases are, for example, pre-feeding of diesel fuel to heating systems and also hydraulic

applications, such as door opening and closing systems.





Service

Application consultation



As a partner in concepts for application-specific gear pumps and pumping systems, Scherzinger provides you with comprehensive support for the fulfillment of your technical and logistic needs, from consultation up to the delivery of spare parts. Our global sales network enables us to respond with individual and flexible solutions to meet your requirements – reliably in good time.

You benefit from

- Individual pump training courses tailored to your knowledge requirements.
- Uncomplicated and expert application consultation worldwide
- Our wealth of experience in processing import, export and customs clearance procedures
- Short-term replacement deliveries within a few workdays
- Professional repairs – your gear pump is returned to you in mint condition



Our wealth of experience and expertise in chemistry and process engineering enables us to give you advice tailored to your requirements.

An expert, highly efficient support and development team provides you with support already in the conception phase of your system.

Based on your specifications, we then design a gear pump solution which provides you with an optimum level of reliability and safety for your application.

This offers important advantages in order to guide you to your goal in an easier and quicker way.

- Precise and quick tender preparation by means of sophisticated software and an extensive media database
- Tested pump concepts provide the basis for your optimum material combination.
- Extensive product documentation already during the tender preparation procedure

Tailor-made gear pump solutions

Do you also require maximum operational reliability for your application? We recognized this requirement at an early stage and have been specializing on customized developments for over 75 years. We place a great emphasis on consistent quality orientation over the entire process chain.

Take the opportunity to engage in close cooperation with our product managers. This will provide you with prompt high-quality solutions tailored specifically to your application case – reliably and precisely.

You will benefit from:

- A highly efficient and expert development team
- The application of modern 3D CAD- CAM-workplaces
- Quick and uncomplicated data exchange for all conventional CAD-Systeme
- Our core competence of processing completely different materials
- FMEA-analysis tools for preventive fault identification
- Quick application-specific adaption of series solutions by our development and prototype design department
- Diverse synergies from experiences gained in large-scale series production and customized productions

Inspection and testing

The optimum, perfect quality of our products is very important to us. "Heart of Hightech" stands for reliability – which we can guarantee by means of detailed testing phases. Not only are new developments subjected to endurance tests under realistic operational conditions, each individual product is also tested for full functionality.

Our modern test field allows tests to be conducted according to your requirements:

- Several individual pump test stations
- Endurance test benches
- Climatic chambers for thermal test
- Noise and pulsation measurements

www.scherzinger-pumps.de



Scherzinger
Pumpen GmbH & Co. KG
Bregstraße 23-25
78120 Furtwangen | Germany
Phone +49 7723 6506-0
Fax +49 7723 6506-40
info@schertzinger.de
www.scherzinger-pumps.de